

AVIOM[®]

AN-16 / i
A-Net Input Module

AN-16 / o
A-Net Output Module

USER GUIDE



Information in this document is subject to change. All rights reserved.

Copyright ©2006 Aviom, Inc.

Printed in USA

Assy. #9310 1004 0001 rev 1.03
P/N 9310 3004 0001 rev 1.0

Aviom, Inc.

1157 Phoenixville Pike, Suite 201
West Chester, PA 19380-4254 USA

+1 610-738-9005 (voice)

+1 610-738-9950 (fax)



www.aviom.com

Aviom and the Aviom logo are trademarks of Aviom, Inc.

A-Net and the A-Net logo are trademarks of Aviom, Inc.

READ THIS FIRST

Important Safety Instructions

1. Read these instructions.
2. Keep these instructions
3. Heed all warnings.
4. Follow all instructions.
5. Do not use this apparatus near water.
6. Clean only with a dry cloth.
7. Do not block any ventilation openings. Install in accordance with the manufacturer's instructions.
8. Do not install near any heat sources such as radiators, heat registers, stoves, or other apparatus (including amplifiers) that produce heat.
9. Do not defeat the safety purpose of the polarized or grounding-type plug. A polarized plug has two blades with one wider than the other. A grounding type plug has two blades and a third grounding prong. The wide blade or third prong are provided for your safety. If the provided plug does not fit your outlet, consult an electrician for replacement of the obsolete outlet.
10. Protect the power cord from being walked on or pinched, particularly at plugs, convenience receptacles, and the point where they exit the apparatus.
11. Only use attachments/accessories specified by the manufacturer.
12. Use only with the cart, stand, tripod, bracket, or table specified by the manufacturer, or sold with the apparatus. When a cart is used, use caution when moving the cart/apparatus combination to avoid injury from tip-over.
13. Unplug this apparatus during lightning storms or when unused for long periods of time.
14. Refer all servicing to qualified personnel. Servicing is required when the apparatus has been damaged in any way, such as when the power-supply cord or plug is damaged, liquid has been spilled or objects have fallen into the apparatus, the apparatus has been exposed to rain or moisture, does not operate normally, or has been dropped.
15. No on/off power switches are included in the system. The external power supply should be used to control power to an Aviom device. This power supply should remain readily operable.
16. The solid line over dashed line symbol () indicates that the input voltage must be a DC voltage.
17. The box within a box symbol () indicates that the external power supply is double insulated.



Aviom, Inc. Limited Warranty

Aviom, Inc. warrants this product against defects in materials and workmanship for a period of **one year** from the date of the original retail purchase.

This warranty does not apply if the equipment has been damaged due to misuse, abuse, accident, or problems with electrical power. The warranty also does not apply if the product has been modified in any way, or if the product serial number has been damaged, modified, or removed.

If a defect is discovered, first write or call Aviom, Inc. to obtain a Return Authorization number. No service will be performed on any product returned without prior authorization. Aviom, Inc. will, at its option, repair or replace the product at no charge to you. The product must be returned during the warranty period, with transportation charges prepaid to Aviom, Inc., 1157 Phoenixville Pike, Suite 201, West Chester, PA 19380. You must use the product's original packing materials for shipment. Shipments should be insured for the value of the product. Include your name, address, phone number, description of the problem, and copy of the original bill of sale with the shipment. The Return Authorization number should be written on the outside of the box.

THIS LIMITED WARRANTY GIVES YOU SPECIFIC LEGAL RIGHTS. YOU MAY HAVE OTHER RIGHTS, WHICH VARY FROM STATE TO STATE (OR JURISDICTION TO JURISDICTION). AVIOM'S RESPONSIBILITY FOR MALFUNCTIONS AND DEFECTS IN HARDWARE IS LIMITED TO REPAIR AND REPLACEMENT AS SET FORTH IN THIS LIMITED WARRANTY STATEMENT. ALL EXPRESS AND IMPLIED WARRANTIES FOR THE PRODUCT, INCLUDING BUT NOT LIMITED TO ANY IMPLIED WARRANTIES OF MERCHANTABILITY AND FITNESS FOR A PARTICULAR PURPOSE, ARE LIMITED IN DURATION TO THE WARRANTY PERIOD SET FORTH ABOVE. NO WARRANTIES, WHETHER EXPRESS OR IMPLIED, WILL APPLY AFTER SUCH PERIOD.

AVIOM, INC. DOES NOT ACCEPT LIABILITY BEYOND THE REMEDIES SET FORTH IN THIS LIMITED WARRANTY DOCUMENT. AVIOM, INC.'S LIABILITY IS LIMITED TO THE REPAIR OR REPLACEMENT, AT OUR OPTION, OF ANY DEFECTIVE PRODUCT, AND SHALL IN NO EVENT INCLUDE INCIDENTAL OR CONSEQUENTIAL DAMAGES OF ANY KIND.

SOME STATES DO NOT ALLOW EXCLUSIONS OR LIMITATION OF IMPLIED WARRANTIES OR LIABILITY FOR INCIDENTAL OR CONSEQUENTIAL DAMAGES, SO THE ABOVE LIMITATIONS MAY NOT APPLY TO YOU.

Warranty Information

Please record the following information for future reference:

Your Authorized Aviom Dealer:

Name: _____

Address: _____

Phone: _____

Serial Numbers of Your Aviom Products: _____

Date of Purchase: _____

Your Authorized Aviom Dealer is your primary source for service and support. The information recorded above will be helpful in communicating with your Authorized Aviom Dealer should you need to contact Aviom Customer Service. If you have any questions concerning the use of this unit, please contact your Authorized Aviom Dealer first. For additional technical support, or to find the name of the nearest Authorized Aviom Repair Station, check the Aviom web site at www.aviom.com.

To fulfill warranty requirements, your Aviom product should be serviced only at an authorized Aviom service center. The Aviom serial number label must appear on the outside of the unit, or the Aviom warranty is void.

This manual and its contents are copyrighted by Aviom, Inc. All rights are reserved by Aviom, Inc. This document may not, in whole or in part, be copied, photocopied, reproduced, translated, or reduced to any electronic medium or machine-readable form without prior written consent from Aviom, Inc.

The software and/or firmware contained within Aviom products is copyrighted and all rights are reserved by Aviom, Inc.

Although every effort has been made to ensure the accuracy of the text and illustrations in this manual, no guarantee is made or implied as to the accuracy of the information contained within.

WARNING!



TO REDUCE THE DANGER OF ELECTRICAL SHOCK DO NOT REMOVE COVERS.

NO USER SERVICEABLE PARTS INSIDE

REFER SERVICING TO QUALIFIED SERVICE PERSONNEL ONLY

- To reduce the risk of fire or electrical shock, do not expose this product to rain or other types of moisture.
- To avoid the hazard of electrical shock, do not handle the power cord with wet hands.
- Operating Temperature: 10°C to 40°C (50°F to 105°F)

CAUTION:

- Using any audio system at high volume levels can cause permanent damage to your hearing.
- Set your system volume as low as possible.
- Avoid prolonged exposure to excessive sound pressure levels.

IMPORTANT:

This equipment has been tested and found to comply with the limits for a Class B digital device, pursuant to part 15 of the FCC Rules. These limits are designed to provide reasonable protection against harmful interference in a residential installation. This equipment generates, uses and can radiate radio frequency energy and, if not installed and used in accordance with the instructions, may cause harmful interference to radio communications. However, there is no guarantee that interference will not occur in a particular installation. If this equipment does cause harmful interference to radio or television reception, which can be determined by turning the equipment off and on, the user is encouraged to try to correct the interference by one or more of the following measures:

- Reorient or relocate the receiving antenna.
- Increase the separation between the equipment and receiver.
- Connect the equipment into an outlet on a circuit different from that to which the receiver is connected.
- Consult the dealer or an experienced radio/TV technician for help.

Changes or modifications to the product not expressly approved by Aviom, Inc. could void the user's FCC authority to operate the equipment.

Table of Contents

Warranty Information	v
Welcome	1
Features	1
AN-16/i Input Module Features:	1
AN-16/o Output Module Features:	1
Conventions Used in this Document	2
AN-Series	2
Using Personal Mixers	2
Cat-5 Cables	2
A-Net Distributors	2
Package Contents	3
AC Line Conditioning	3
Installing AN-Series Products in a Rack	4
The EtherCon Connector	4
What is Category 5?	5
Cable Lengths	6
About A-Net	7
Power Supplies	8
Cleaning and Maintenance Information	9
Front/Rear Panel Descriptions	10
AN-16/i Input Module Front Panel	10
AN-16/i Input Module Rear Panel	11
AN-16/o Output Module Front Panel	12
AN-16/o Output Module Rear Panel	13
The AN-16/i Input Module	14
AN-16/i Front Panel	14
Channel LEDs	14
Input Level Switch	14
The Stereo Link Switch	15
Power LED	16
AN-16/i Rear Panel	17
A-Net Connections	17
Channel Input Jacks	18
Channel Thru Jacks	18
The AN-16/o Output Module	19
Channel LEDs	19
Output Level Switches	19
AN-16/o Output Module Rear Panel	20
DC Power Input	20
A-Net Connections	21
Audio Outputs	21
A-Net Connection Options	21
Series connection of A-Net devices	22
Parallel A-Net Routing	22

Connecting Audio	23
Connections on the AN-16/i Rear Panel	23
Connecting a Mixer	23
Direct Output	23
Submixing	24
Bus Outputs	24
Aux Sends (Effects Sends)	25
Insert Send/Return Points	26
Adding Effects	28
Line-level Devices	28
Connections on the AN-16/o Rear Panel	29
Adding More Audio Outputs	29
Adding Pro16 Personal Mixers	30
Euroblock Connections	31
Audio Networks	32
32-Channel Systems	32
A-Net Expansion	32
32 Channels Send	33
16 Channels Send/Return	34
Adding More Audio Outputs	36
Adding an A-16D Distributor	37
64-Channel Systems	37
System Bridge	38
Connecting the System Bridge	39
Configuration Notes	40
Expanding a Network	41
Using Multiple System Bridges	42
Appendix 1	45
AN-16/o Output Module Variations	45
Original AN-16/o Output Module Front Panel	47
Original AN-16/o Output Module Rear Panel	48
Appendix 2	49
DB25 Wiring Info	49
AN-16/o DB25 Audio Connections	49
DB25 Pinout	49
Warranty Registration	56

Welcome

Thank you for purchasing the **Aviom AN-16/i Input Module** and **AN-16/o Output Module**. This User Guide is designed to familiarize you with your new products and to have you up and running in no time.

Features

The AN-16/i and the AN-16/o are part of Aviom's Pro16 audio networking products. Together, they provide a host of professional features designed to make the system flexible in a variety of audio, performance, and music situations. By combining AN-16/i and AN-16/o units, a wide variety of digital snake configurations are possible.

AN-16/i Input Module Features:

- Sixteen line level audio inputs
- High quality A-to-D conversion
- Adjustable input gain switches per channel pair
- Eight stereo channel Link switches
- Signal and Peak LEDs on each channel
- A-Net Out and Expansion jacks
- 1U-high rack-mountable enclosure

On TRS-equipped models:

- Sixteen balanced 1/4-inch TRS jacks for audio Input connections
- Sixteen balanced 1/4-inch TRS jacks for audio Thru connections

On Euroblock-equipped models:

- Sixteen balanced Euroblock connectors for audio Input and Thru connections

AN-16/o Output Module Features:

- Sixteen balanced line level outputs
- Adjustable output gain switches per channel pair
- Signal and Peak LEDs on each channel
- A-Net In, Out, and Expansion jacks
- 1U-high rack-mountable enclosure

On DB25-equipped models:

- Two d-sub DB25 multipin audio Output connections, each carrying eight channels of balanced audio data

On TRS-equipped models:

- Sixteen balanced 1/4-inch TRS jacks for audio output connections

On Euroblock-equipped models:

- Sixteen balanced Euroblock connectors for audio Output connections

Conventions Used in this Document

AN-Series

The AN-16/i Input Module and AN-16/o Output Module are referred to generically as the ***AN-Series*** of products.

All rear-panel audio connection information refers to both the TRS and Euroblock versions of the products unless otherwise noted.

When describing distributed audio network configurations, the AN-16/i-M Mic Input Module can be substituted anywhere the AN-16/i is used.

Using Personal Mixers

It is possible to create an audio distribution and personal monitor system using any combination of Aviom AN-Series and Personal Mixer products, including the A-16, A-16II, and A-16R. In some cases the information in this document can refer to either the table-top version of the Personal Mixer, or the rack-mounted A-16R version.

When referring to the use of the mixers in an A-16 System in general, the terms ***A-16 Mixer*** or ***Personal Mixer*** are used to describe a case where a standard A-16 or A-16II Personal Mixer, the A-16CS remote Control Surface, or a rack mounted A-16R Personal Mixer can be used.

Cat-5 Cables

In most cases Cat-5e and Cat-6 cables can be interchanged. When speaking about interconnections between components in a system, the term *Cat-5* is used generically to indicate the use of any of the applicable cable types.

A-Net Distributors

The A-16D and A-16D Pro A-Net Distributors are referred to generically as *A-Net Distributors*.

Package Contents

A complete AN-Series distributed audio network system comes packaged in two parts, the AN-16/i Input Module and the AN-16/o Output Module. Many configurations are possible by using additional AN-16/i Input Module and/or AN-16/o Output Module units. Check the contents of the boxes carefully before making connections and continuing with installation.

To create a basic distributed audio system you should have:

An AN-16/i Input Module box with

- One AN-16/i Input Module
- One DC Power supply for the AN-16/i

An AN-16/o Output Module box with

- One AN-16/o Output Module
- One DC Power supply for the AN-16/o

Options for your system include

- Category 5e interconnect cables
- The AN-16SBR (or AN-16SB) System Bridge
- Aviom Personal Mixer products such as the A-16II Personal Mixer or A-16R rack mount Personal Mixer for creating a monitoring system
- A-16D and/or A-16D Pro A-Net Distributors

Also included with the system is a Warranty Registration, found within this User Guide. Be sure to fill out the form and return it to Aviom, Inc. via mail or fax as soon as possible.

AC Line Conditioning

Aviom products are digital devices and as such are sensitive to sudden spikes and drops in the AC line voltage. Changes in the line voltage from lightning, power outages, etc. can sometimes damage electronic equipment.

To minimize the chance of damage to your equipment from sudden changes in the AC line voltage, you may want to plug your equipment into a power source that has surge and spike protection. Power outlet strips are available with built-in surge protection circuits that may help protect your equipment.

Other options for protection of your equipment include the use of an AC line conditioner or a battery backup system (sometimes referred to as an *uninterruptible power supply*, or UPS).

Installing AN-Series Products in a Rack

The AN-16/i Input Module and the AN-16/o Output Module are designed to be installed in a standard 19-inch audio equipment rack. This design is both for easy transportation of the units and for protection. Each unit takes up one standard rack space (19 inches wide by 1.75 inches high). Optionally, you can place the units on a table top or other flat surface such as a shelf.

The rack ears on each side of the device are designed to support the weight of the AN-16/i or AN-16/o without additional hardware. Each rack ear contains holes for two screws per side. Always support the unit with all four screws.

To rack mount either of the AN-Series products, position it in the equipment rack at the desired location. Use standard rack-mounting screws (10-32 size) to attach the unit to your rack hardware. Tighten all four screws firmly, but avoid overtightening.

You may want to use non-metallic washers between the rack-mounting screws and the device's finished surface to avoid marring the painted finish on your Aviom products.

Always allow adequate ventilation for devices mounted in equipment racks. Avoid placing your AN-16/i or AN-16/o directly above or below other rack-mounted devices that produce high levels of heat, such as power amps.

The EtherCon Connector

Some Aviom products use EtherCon Cat-5 connectors. The Neutrik EtherCon connector is a dual RJ45 type connector. It can receive a standard Category 5e cable or a cable fitted with the special heavy-duty EtherCon connector.

When using a standard Cat-5e cable, plug the cable into the center of the jack; release the cable by pressing on the small plastic tab built into the cable connector.

The locking EtherCon connector is similar to an XLR cable, the kind commonly used on microphones. Insert an EtherCon equipped cable into the jack until it clicks and locks in place. To remove the cable, press on the metal release tab at the top of the panel-mounted EtherCon jack and pull the connector outward.

What is Category 5?

Category 5 (sometimes referred to as *Cat-5*) describes a commonly used type of high performance network cabling. It is used mainly for data transmission purposes to connect computers, modems and other devices. A standard Category 5 patch cable consists of four twisted pairs of copper wire terminated by RJ45 male connectors. The cable assembly is used to provide connectivity between any two Category 5 female outlet jacks. A variation, called Category 5e (or Cat-5e), uses additional twists in the cable to reduce interference in high-speed network applications. In general, when using long cable lengths, select cat-5e cables for best performance. **Aviom suggests the use of Cat-5e cables or better for all A-Net applications.**

The RJ45 connector looks similar to the connectors found on a telephone system, only larger. The twisting of the wire pairs helps to shield the cable from unwanted interference from electrical fields or radio interference (sometimes referred to as "RF"). Cat-5 cabling supports frequencies up to 100 MHz and speeds up to 1000 Mbps.

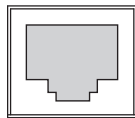

RJ45 Jack

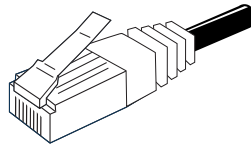

Cat-5 Cable

Cables Used in the Aviom System

The Category 5 cables used with your Aviom system are interchangeable with any standard Category 5e (Cat-5e) cables. If you need a longer cable for a particular application, any computer store should be able to supply you with an appropriate cable. A qualified technician should be able to build custom cables to any length (up to the maximum of 500 feet (about 150 meters) between components).

For fixed or permanent installations, you have the option of running Cat-5 cables inside walls and terminating them with readily available wall panel connectors that include the RJ45 jack. (Solid wire is recommended for permanent installations.)

In addition to standard Category 5e cables, Category 6 (Cat-6) cables can also be used.

Note: When purchasing Category 5e cables, be sure to buy only standard Cat-5e cables, not those sold as *crossover* cables. A crossover cable is used for file transfer between two computers. A crossover cable is **not** compatible with your Aviom equipment.

Cable Lengths

Cat-5e cables used with your Aviom products can be up to 500 feet (approximately 150 meters) in length. The maximum cable length specification applies to the cable connected between the AN-16/i Input Module and the first AN-16/o Output Module (or Personal Mixer) in your system as well as for cable runs between each additional A-Net Pro16 compatible device in your system.

Your cable length performance will be affected by a number of factors including the quality of the cables used, and the number of devices such as cable couplers used or wall panel interconnections in use. Use Cat-5e cable for best performance wherever possible.

Up to 500 feet of Cat-5e cable can be used to connect each system component



AN-16/i Input Module



AN-16/o Output Modules or Personal Mixers



Infinite number of A-Net components

When using the optional AN-16SB System Bridge, the cable length specification applies to the *total* cable length between the two A-Net devices being connected with the AN-16SB. This is similar to what happens when using an inline coupler to extend cable lengths.

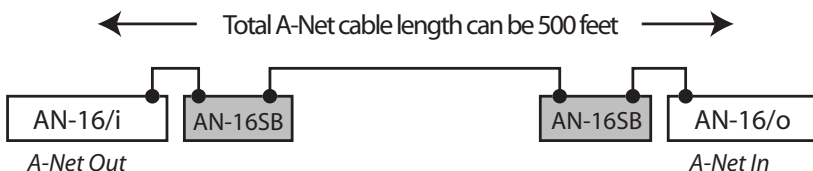

Pre-made cables in a variety of lengths and colors are available at most computer outlets. Cables can be extended by using a simple passive device called an *inline coupler* to add length to existing cables (as long as you do not exceed the specified maximum cable length). If you need a longer cable on occasion, this is a simple solution. Note that it is possible that the maximum cable length specification can be compromised by using inline couplers or other passive connection devices.

About A-Net

Aviom's A-Net Pro16 is a high-speed data transmission protocol. It is capable of sending and receiving high-quality digital audio using readily available Category 5 cables. The A-Net technology is a proprietary system developed by Aviom.

A-Net is based on the physical layer of Ethernet, a Local Area Network (or LAN) technology. This provides A-Net with a mature and robust base on which to build.

As used in your AN-Series Products, the A-Net signal carries sixteen channels of digital data from the AN-16/i Input Module to each A-Net device connected to the system.

Some of the benefits of using A-Net to transmit digital audio are:

- Virtually no latency
- No ground loops
- Easy cabling using readily available components
- An unlimited number of A-Net devices can be used in a system
- Ease in spanning long distances between system components

Note: While the Cat-5e cables and connectors used on your Aviom products look like typical computer network connections, do not connect computers, routers, or other home and business networking equipment to your Aviom products.

Power Supplies

Your Aviom product uses a DC power supply that has a two-prong power cord. The prongs on the power supply are identical, meaning that there is no need to orient the plug in a specific direction in the power outlet. Some products with two-prong power cords have polarized plugs that can only be inserted into an electrical outlet one way.

The power supply that is shipped with your Aviom product is a universal switching type. It is capable of working with voltages from 90 to 240 volts AC. This means that a separate power supply is not needed to use the products with the AC power systems found in most countries. You should always use the power supply that shipped with your product. When travelling, you may need plug adapters to use the power supply with the AC outlet plug shape variations in use throughout the world.

Should you need to replace the power supply that came with your product, we recommend using only a power supply that meets the following specifications.

Type:	Switching	
Input Voltage:	90-240 volts	50/60Hz 30VA
Output:	24Vdc	0.5A
Polarity	Outer = negative; Inner = positive	
Plug Size	2 mm	



Note that polarity of the plug found on the DC power supply needs to match that of the original power supply that came with your Aviom equipment. Aviom products use a center positive power supply. The outer contact is negative, the inner contact is positive. (See the diagram above.)

Cleaning and Maintenance Information

The exterior of your Aviom products should be cleaned with a dry, soft, lint-free cloth. For tougher dirt, you can use a cloth slightly dampened with water or with a mild detergent.

When cleaning your Aviom products, never spray cleaners directly onto the product surfaces. Instead, spray a small amount of the cleaning solution onto a clean cloth first. Then use the dampened cloth to clean the product.

Note: Never use solvents or abrasive cleaners on the finished surfaces of your Aviom products.

Front/Rear Panel Descriptions

AN-16/i Input Module Front Panel

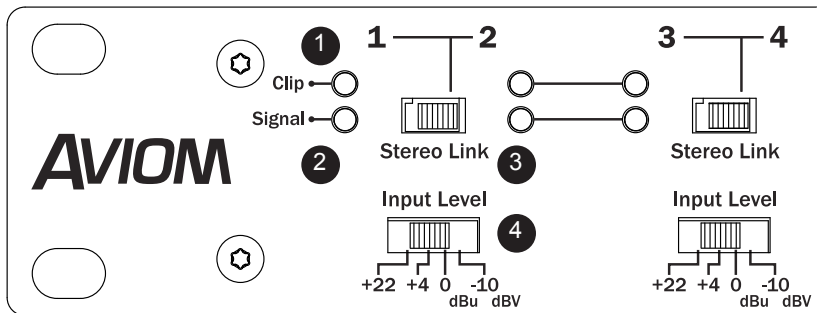

FUNCTION	
1	Clip LED, red - lights when the audio signal is 3dB below full scale (0dB)
2	Signal Present LED, green - lights to show that an audio signal is present on a channel
3	Stereo Link Switch - in the left position, each channel is mono; in the right position, the channels are linked as a stereo pair
4	Input Level Switch - selects one of four available operating levels; selectable for each channel pair
5	Power LED - indicates that the AN-16/i is on

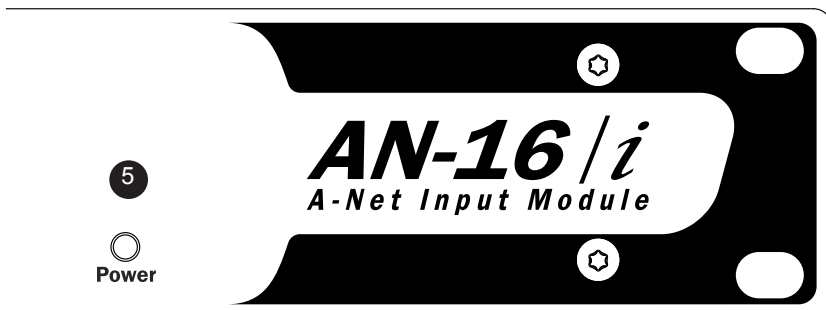

AN-16/i Input Module Rear Panel

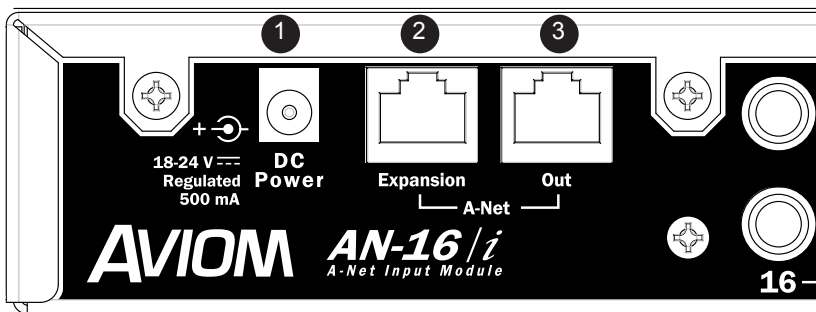

FUNCTION	
1	DC Power Jack - connect the DC power supply here
2	A-Net Expansion Jack - used when creating a 32-channel system with two AN-16/i and two AN-16/o units
3	A-Net Out Jack - connects to any A-Net compatible device
4	Analog Audio Input - TRS balanced 1/4" jack accepts any line level audio signal (for TRS model only)
5	Thru Jack - a copy of the balanced analog audio from the In jack
6	Euroblock inputs (for EB model only)

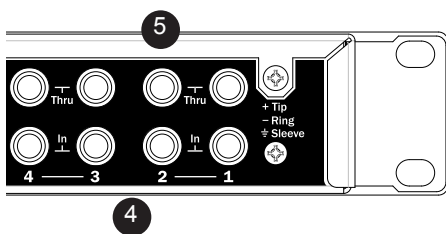

TRS model rear panel

Euroblock model rear panel

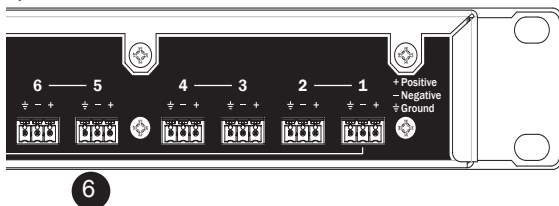

AN-16/o Output Module Front Panel

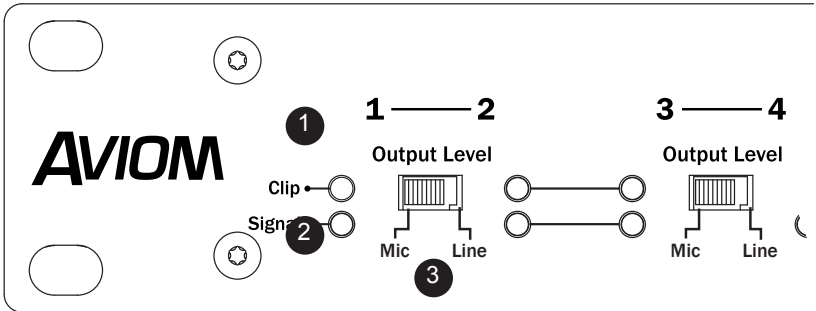

FUNCTION	
1	Clip LED, red - lights when the audio signal hits (0dB) full scale, indicating that the source audio signal is too high.
2	Signal Present LED, green - lights to show that an audio signal is present on a channel
3	Output Level Switch - in the left position, the channel pair is output at mic level; in the right position, the channels are output at +4dBu line level
4	Power LED - indicates that the AN-16/o is on
5	A-Net LED - indicates that the AN-16/o is receiving valid A-Net data

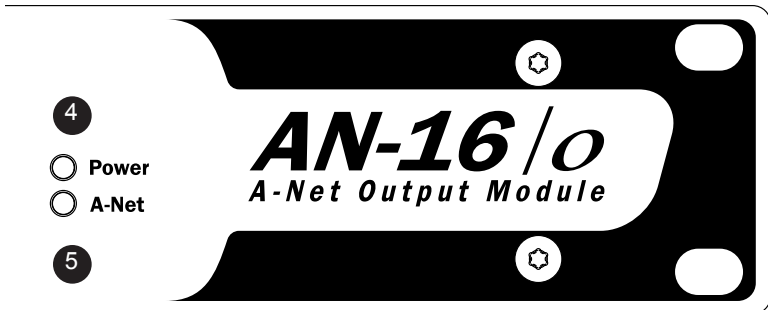

AN-16/o Output Module Rear Panel

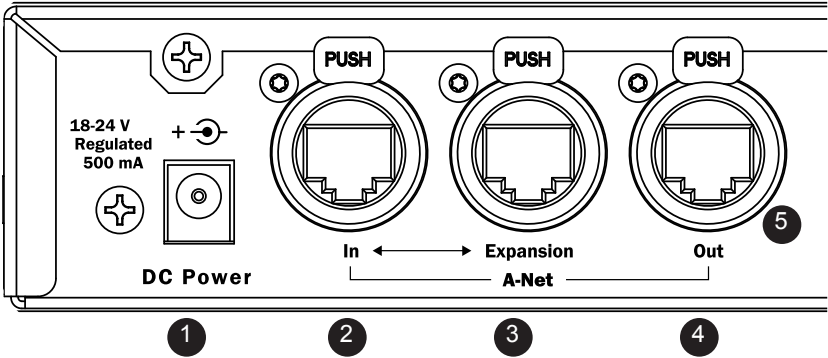

FUNCTION	
1	DC Power Jack - connect the DC power supply here
2	A-Net In Jack - used when creating a 32-channel system with two AN-16/i and two AN-16/o units
3	A-Net Expansion Jack - used when creating a 32-channel system with two AN-16/i and two AN-16/o units
4	A-Net Out Jack - connects to any A-Net compatible device
5	EtherCon RJ45 jacks
6	Analog Audio Outputs - DB25 d-sub jack supplies a balanced line-level audio signal; eight channels per jack

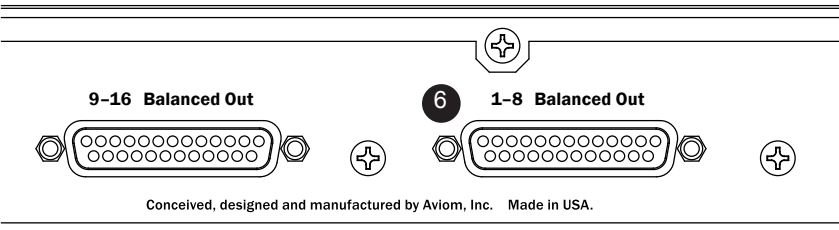

Conceived, designed and manufactured by Aviom, Inc. Made in USA.

The AN-16/i Input Module

This section explains the basic layout of your new Aviom products. The diagrams on the previous pages can be used as a quick visual guide to the location of the components of the AN-Series products mentioned in this section.

AN-16/i Front Panel

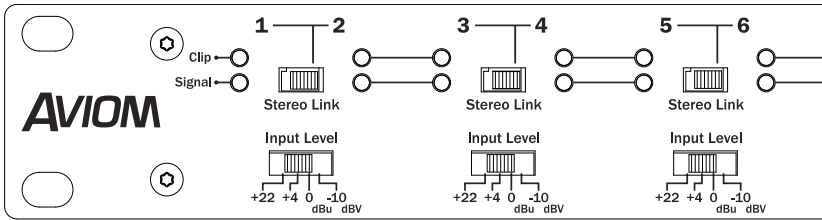

The front panel of the AN-16/i contains the Channel information, Stereo Link switches, Signal Present LEDs, Clip LEDs, Power indicator, and the Input Level switches.

Channel LEDs

The numbered Channels on the AN-16/i front panel correspond to the sixteen line-level analog audio inputs on the rear panel of the AN-16/i. They are grouped together in pairs — Channels 1 and 2, Channels 3 and 4, etc. Each Channel contains two LEDs, one showing that there is an audio signal present, and another used to indicate that the input to a channel is causing audio clipping. Signal and Clip LEDs appear directly beneath the Channel numbers.

The lower LED, marked *Signal*, will light as long as an audio signal of at least -40dB is present on the channel. It provides an easy way to confirm that audio is indeed passing into—and being processed by—the AN-16/i.

The upper LED is marked *Clip*. It will light if a signal reaches a point that is within 3 dB of full scale (0dB). In general, you want to operate the system so that the Clip LED lights only occasionally. If the LED is on constantly, you should either lower the volume of the source audio coming into the AN-16/i or try different Input Level settings.

Input Level Switch

The AN-Series of audio network products have been designed to accept a wide range of professional and semi-professional audio levels. There are four Input Level gain settings available. Changes to the input level on the AN-16/i front

panel affect a pair of channels at a time.

The four levels are +22dB, +4dB, 0dBu, and -10dBV. To select the proper Input Level setting, choose the Input Level position that most closely matches the output of your audio gear. Here are some examples to be used as a guide:

- Use the +22dB setting for the hottest signals such as those coming from professional broadcast equipment, tape decks, and some digital audio workstations (DAWs).
- The +4dB setting is the best choice for most professional audio gear such as mixing boards, microphone preamps, effects processors, etc.
- Try the 0dBu setting for musical instruments such as keyboards and drum machines.
- The -10dBV setting is appropriate for consumer audio devices such as CD players and MP3 players. Also, semi-pro audio gear should use the -10dB setting. (In many cases those devices use RCA jacks for audio input and output.)

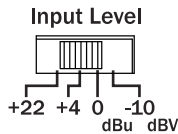

Check the specifications of your audio gear if you are unsure about its output level. Although you won't harm the AN-16/i or your audio devices by using an incorrect level setting, you do want to avoid distorting the audio that passes through the system.

In general, you need to check the AN-16/i front panel Signal and Clip LEDs when initially setting up your audio system and choosing level settings. If your -10dB device outputs a hot level, it may be necessary to adjust the Input Level switch to avoid clipping. In this example, moving the switch to the 0dB setting should provide a strong signal without distortion.

The Stereo Link Switch

The AN-16/i Input Module provides an easy solution for stereo input sources such as CD players, mixer sub-groups, keyboards, effects device outputs, etc. when incorporating the AN-16/i into a personal monitoring system.

When using the AN-16/i Input Module with AN-16/o Output Modules alone to create a distributed audio network, the setting of the Stereo Link switch will have no effect. The Stereo Link switch is most useful when used to turn a pair of adjacent channels into a stereo channel that can be controlled as a single source on the Pro16 series of Personal Mixers.

There are eight Stereo Link switches on the front panel of the AN-16/i. They can be used in any combination, as your needs require. The Stereo Link switch is located between two channels—one odd and one even. Stereo Links always affect adjacent channels (for example, channels 1 and 2, channels 13 and 14, etc.).

The default setting, with the switch to the left, allows independent control of each input channel from Personal Mixers connected to the system. To link channels together as a stereo input, move the Link switch to the right. (Moving the switch to the Link position causes all Personal Mixers, including the A-16CS Control Surface, connected to the system to instantly update their channel status.)

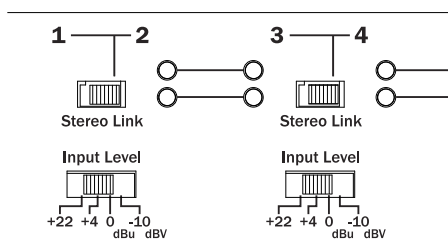

Some things to keep in mind about linked channels:

- The position of the Stereo Link switch does *not* affect the audio in the AN-16/o Output Module.
- Linking channels affects *all* Personal Mixers connected to the system.
- Any combination of stereo and mono channels can be used.
- If you want to control two input channels as a stereo source, they must be connected to an odd and even pair of channels, as indicated by the graphics on the AN-16/i front panel.
- Changes to the Stereo Link status can be made on the fly, with audio running through the system.
- All Personal Mixers will instantly update their channel status if the Link switch position is changed for any channel pair.
- The Link status is not saved when you create a Preset on A-16, A-16II or A-16R Personal Mixers.
- Changing the channel link status will affect Groups you have created on Personal Mixers in some cases.

Power LED

The right side of the AN-16/i Input Module also contains the Power LED. This indicator shows that power is connected to the unit. When the AN-16/i is powered up, a valid A-Net signal is being generated.

AN-16/i Rear Panel

On the rear of the AN-16/i Input Module you will find the DC power connector, A-Net connections, the sixteen balanced analog audio inputs, and the sixteen audio Thru jacks. (No Thru jacks appear on Euroblock models)

Signal routing into and out of the AN-16/i Input Module has been designed to be extremely flexible, allowing the AN-16/i to integrate into virtually any audio environment.

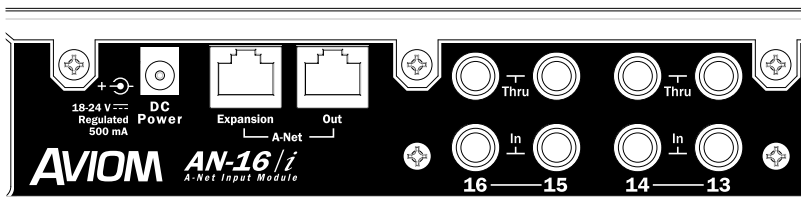

Power Connector

The AN-16/i Input Module comes with a switching-type power supply. This type of power supply can be used with a wide range of AC wall current outputs. This means that you do not need to replace the power supply if the unit will be used in countries where current voltages are different if you travel with your Aviom gear occasionally. (You may, however, need plug adapters to allow the power supply to be connected to wall outlets internationally since many countries use different physical plug layouts for their power systems.)

A-Net Connections

Two A-Net connections appear on the rear panel of the AN-16/i, They are marked A-Net Expansion and A-Net Out.

A-Net Out

The A-Net Out jack sends the A-Net data from the AN-16/i to an A-Net compatible device such as the AN-16/o Output Module. Use any standard Cat-5e cable for connections between devices. Remember that the maximum cable length between devices is 500 feet (150 meters).

When a proper A-Net connection between the AN-16/i Input Module and an AN-16/o Output Module (or Personal Mixer) exists, the A-Net Active LED on the receiving device will light.

A-Net Expansion

The A-Net Expansion jack is used when creating a 32-channel audio network using at least two AN-16/i Input Modules and two AN-16/o Output Modules. Using the A-Net Expansion jack allows all thirty-two channels of data to travel down a single Cat-5e cable up to 500 feet (150 meters) to the destination AN-16/i or AN-16/o units.

Channel Input Jacks

The rear panel of the AN-16/i Input Module contains sixteen Input jacks (labeled *In*). These jacks can accept balanced or unbalanced signals on ¼-inch plugs (TRS) or Euroblocks, depending on the model you have selected.

Balanced signals (sometimes referred to as *TRS*, for Tip, Ring, and Sleeve) are found on many professional audio devices. The ¼-inch connector used for balanced audio wiring has three conductors: the tip, the ring, and the sleeve. The balanced wiring system is ideal for keeping noise out of the audio signal from sources such as radio interference (sometimes called "RF").

Unbalanced audio signals are found on many effects processors, music keyboards, and consumer electronics. Only two connectors are used, the tip and the sleeve. A standard musical instrument cable (sometimes called a guitar cord) uses this configuration, for example.

Channel Thru Jacks

The sixteen balanced audio Thru jacks on the TRS version of the AN-16/i provide the user with an exact copy of the signal plugged into the In jack just below it. This can be used as a way to insert the AN-16/i Input Module into a signal chain without giving up audio patching flexibility.

To provide a Thru function with a Euroblock-equipped AN-16/i, simply connect two sets of wires to each terminal of the Euroblock connector.

The AN-16/o Output Module

This section briefly explains the features and functions of the AN-16/o Output Module.

AN-16/o Output Module Front Panel

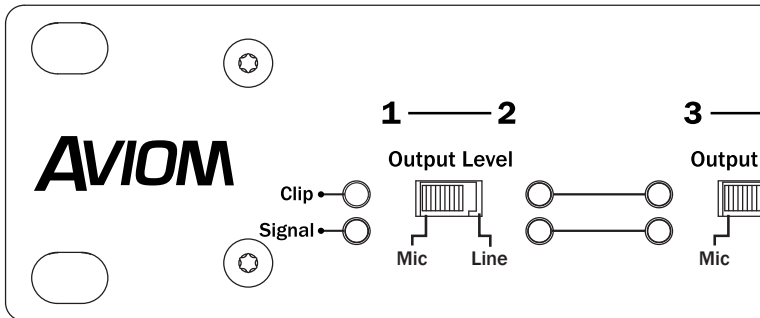

The front panel of the AN-16/o Output Module contains the Channel information, Output Level switches, Signal Present LEDs, Clip LEDs, the A-Net LED, and the Power indicator.

Channel LEDs

The sixteen numbered Channels on the AN-16/o front panel correspond to the line-level analog audio outputs on the rear panel. Each Channel contains two LEDs, one showing that there is an audio signal present, and another used to indicate that the input to a channel is causing audio clipping. Signal and Clip LEDs appear directly beneath the Channel numbers.

The lower LED, marked *Signal*, will light as long as an audio signal of at least -40dB is present on the channel. It provides an easy way to confirm that audio is present on a channel of the AN-16/o Output Module.

The upper LED is marked *Clip*. It will light if the input signal coming into your AN-16/i Input Module is too high, causing the audio outputs of the AN-16/o to sound distorted. In general, you want to operate the system so that the Clip LED on the AN-16/i Input Module lights only occasionally. If the LED is on constantly, you should either lower the volume of the source audio coming into the AN-16/i or try different Input Level settings.

Output Level Switches

The AN-16/o has been designed to work with a wide range of professional and semi-professional audio gear. There are two Output Level settings available on the

front panel, mic and line.

The **LINE** setting is the best choice for most +4dB professional audio gear such as mixing boards, microphone preamps, recording devices, effects processors, etc.

The **Mic** setting is appropriate for use with the mic preamp input on mixing consoles, audio interfaces for DAWs, etc. Use this setting if the console you are connecting to has no available line-level inputs.

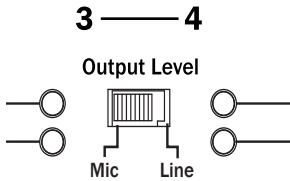

Check the specifications of your audio gear if you are unsure about its output level. Although you won't harm the AN-16/i or your audio devices by using an incorrect level setting, you do want to avoid distorting the audio that passes through the system.

AN-16/o Output Module Rear Panel

On the rear of the AN-16/o Output Module you will find the A-Net connectors, the power supply input, and the balanced line-level audio outputs.

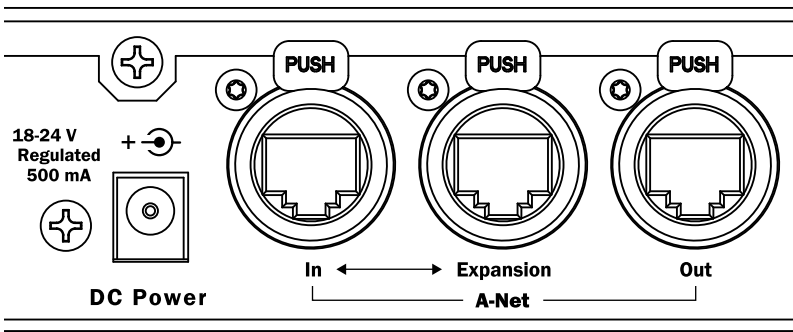

DC Power Input

Connect the 18-24v DC power supply to the jack on the rear of the AN-16/o Output Module. Use only power supplies designed for use with your Aviom products.

A-Net Connections

There are three A-Net connectors on the rear of the AN-16/o Output Module, marked In, Expansion, and Out.

A-Net In

The A-Net In jack accepts

- the A-Net signal coming from an AN-16/i or AN-16/i-M Input Module, Y1 card (Yamaha) or D-16c card (DiGiCo)
- A-Net from the Expansion jack of an AN-16/o or an AN-16/i or AN-16/i-M
- the A-Net signal coming from the Out jack of a Personal Mixer
- the A-Net Out signal from an A-16D or A-16D Pro A-Net Distributor

A-Net Out

The **A-Net Out** jack is used to connect the incoming digital A-Net data to another A-Net device. This will send the same sixteen audio channels being processed by the AN-16/o Output Module to the next A-Net device, creating a digital split. An unlimited number of A-Net devices can be connected in series using this method. Any A-Net device, including the A-16D or A-16D Pro A-Net Distributors can be connected here.

A-Net Expansion

The **A-Net Expansion** jack is used when a 32-channel system is created by using two AN-16/i (or AN-16/i-M) Input Modules and two AN-16/o Output Modules. Using A-Net Expansion allows thirty-two channels of audio to travel down a single cable, up to the maximum of 500 feet, 150 meters.

Audio Outputs

The outputs on the rear of the AN-16/o Output Module can be used with any device that can accept a line-level audio output, such as recording devices, mixing consoles, wireless transmitters, powered speaker systems, and computer sound cards.

The outputs on the AN-16/o are balanced line-level audio. The output jacks are DB25 d-sub multipin connectors; each outputs eight channels of audio.

A-Net Connection Options

In a simple system, the easiest connection method uses what is called a *daisy-chain*. That is, each A-Net device is connected in series. The first device in the chain receives the A-Net signal from the AN-16/i Input Module. Each successive A-Net compatible device gets its A-Net connection from the A-Net Out jack of

the device preceding it in the chain.

There is one drawback to this connection method, however. If one A-Net device in the chain is disconnected from the A-Net signal chain, all units beyond this point will not get any audio until the unit is reconnected to a valid A-Net source.

Series connection of A-Net devices

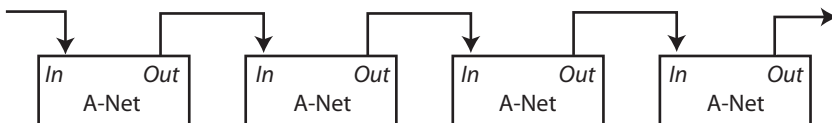

In this diagram, A-Net is connected from device to device using Cat-5e cable. The A-Net Out port on the first device connects to the A-Net In port on the next, and so on.

A parallel A-Net connection solves that problem. By using the optional A-16D or A-16D Pro A-Net Distributor, parallel A-Net connections are possible. In fact, any combination of series and parallel connections can be used to solve even the most complex audio routing problems.

Parallel A-Net Routing

Using an A-16D A-Net Distributor

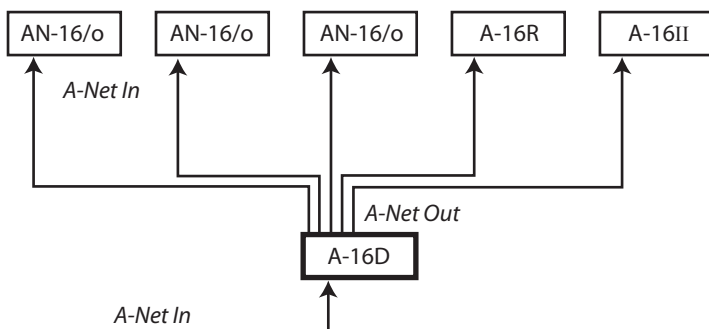

Here, a variety of A-Net compatible components are shown connected in parallel to an A-Net Distributor (either the A-16D or A-16D Pro). The A-Net signal from the Distributor is connected to each A-Net compatible device with a Cat-5e cable. Removing one A-Net device has no effect on the other A-Net outputs being used.

Connecting Audio

There are many ways to get audio into the AN-16/i Input Module for processing. Depending on your application—studio, stage, broadcast, etc.—the types of signals and equipment available will vary. This section will give examples of some typical setups that you can modify to suit your individual needs.

Connections on the AN-16/i Rear Panel

There are two rows of balanced TRS connectors marked **In** and **Thru** on the rear of the TRS version of the AN-16/i Input Module. A single row of Euroblock connectors are provided on the EB versions of the product.

The connections on the TRS-equipped AN-16/i can accept balanced or unbalanced ¼-inch cables. Euroblock models can be wired to a variety of connectors, making them ideal for application where TRS cables are not appropriate. The system can accept a wide variety of signal levels; gain settings are changed on the front panel of the AN-16/i.

The audio design of the AN-16/i allows you to add the system at virtually any point in your existing audio system. The AN-16/i can accept audio coming from:

- Mixing board direct outputs
- Mixing board insert sends only
- Mixing board insert send and return loops
- Line output from mic preamps
- Line outputs from keyboards and other music devices
- CD or DVD players
- Tape decks
- Digital Audio Workstations (DAWs)
- Computer sound cards
- Effects processors
- Video decks, cameras, etc.

Connecting a Mixer

As mentioned above, almost any line-level audio output can be used with the AN-16/i. Depending on the topology of your particular audio mixer, some or all of the following signal types could be available.

Direct Output

A direct output is typically found at the channel level of a console. That is, each channel on the mixer has its own direct output jack. This type of output sends an exact copy of the audio signal present in each channel out of the mixer without interrupting the signal being sent to the main part of the mixer.

If your mixer has direct outputs available, a cable from each channel that you want to be part of the audio network is connected to the AN-16/i inputs. A maximum of sixteen direct outputs can be plugged into a single AN-16/i Input Module. For systems requiring more than sixteen channels, multiple AN-16/i Input Modules can be configured.

Submixing

If you have more than sixteen direct outputs from a mixer that need to be monitored in a system using only one AN-16/i, then some of the channels will need to be submixed. This can be accomplished on most consoles by using a bus output (referred to as a *group* output on some consoles), described below. A submix is simply a selected group of channels assigned to a single output.

Bus Outputs

A bus (or group) output is typically used to route audio signals to a recording device or to control the volume of a group of channels from a single fader. Most mixers equipped with bus outputs have fewer bus outputs than channels. Four, eight, or sixteen bus outputs are common mixer configurations.

To use a bus output with the AN-16/i Input Module, the individual channels in your mixer need to be assigned to the desired bus output. This is usually done with a selector button located somewhere within each channel strip. Assigning a channel to a bus output does not remove the signal from the main mix. (Some mixers do allow the option, however.) Specific instructions about how to use your particular mixer in this case are beyond the scope of this document. Consult your mixer's documentation to learn more.

With a number of channels assigned to a bus output, you can then control the level of the bus independent of the other levels on the mixer. The individual channel level fader is used to set the relative balance of all channels assigned to the bus.

The following example shows a typical mixer. Five of the audio channels are first assigned to bus #1 using the buttons in the channel strip. This routes their audio signals to the bus output faders seen on the right side of the mixer. The level for the combined channels is set by this fader. The output of the bus fader can be patched as needed to a monitoring system, audio distribution network, recording device, etc.

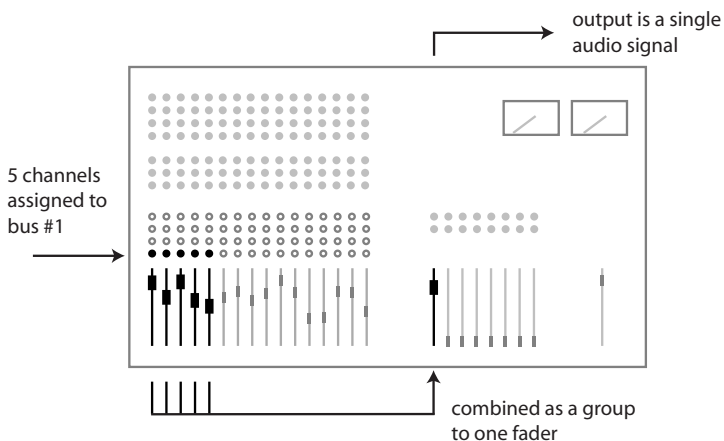

Using a Bus Output

As an example, all the channels of the main mixer devoted to drums can be assigned to a bus. As mentioned previously, the relative mix of all the components of the drum sound would remain the same; the levels are based on the individual channel's level settings. By sending all the drum channels to a bus, the entire drum kit's volume can be raised or lowered from a single fader.

Stereo Drum Mix Example

By using two bus outputs, a stereo drum sub-mix with panning can be created. The drums are assigned to two bus outputs, usually consecutive numbers such as 1 and 2, or 3 and 4. The stereo pan (or left/right balance) from the drum kit is then set by using the mixer's Pan knobs. To get the floor tom into only the right speaker, for example, its pan knob should be turned to the fully clockwise position.

Aux Sends (Effects Sends)

An Auxiliary Send (also called an Aux Send or effects send) is typically used on a live or recording console to send the sound from a channel into an effect device such as a reverb. Using a dedicated set of knobs found in each channel strip, each channel can have a different amount of the effect applied as needed.

An Aux Send does not have to be used exclusively with effects, though. You can think of an Aux Send as another mini mixer; it functions in a similar manner to a bus output. It is used to pass the audio signals from the console to another destination. You can use any combination of available audio sources with the AN-16/i Input Module.

The method for using an Aux Send to create a monitor mix is similar to that described for using a bus output. Most consoles have from two to eight Aux

Sends. Some console designs also allow Aux Sends to be pre- or post-fader. The number of independent audio signals that can be sent to the AN-16/i Input Module via Aux Sends will depend upon the design of the mixing console you are using.

The following diagram shows multiple mixer channels sending various amounts of signal to one aux send. The master output of the aux send is fed to an input on the AN-16/i Input Module.

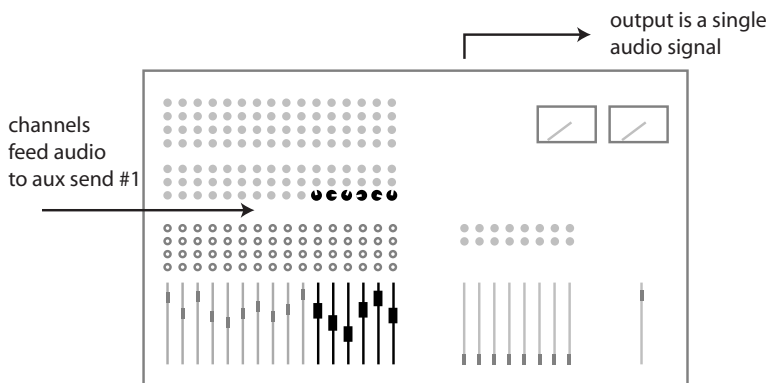

Insert Send/Return Points

The insert loop on an audio mixer is typically used as a means of extending the processing capabilities of the mixer on a channel-by-channel basis. An effects device such as a compressor can be added to the channel so that only that specific channel is affected by the processing.

An insert on a mixer consists of a *Send* and a *Return*. The Send is used to get the channel's audio into the effects processor. The processed signal coming from the effects device goes back to the console via the Return path.

The physical jack layout of an effect Send/Return loop on a console varies depending on the model and manufacturer.

TRS Inserts

Some consoles use a single jack to perform both send and return functions. In this case the jack would use tip-ring-sleeve (TRS) wiring, with one of the signal wires performing the Send function, the other being used for the Return. Both Send and Return share the common ground wire. For TRS inserts, it is common to use a "Y" cable, one that has a TRS plug on one end and then a split into two mono tip-sleeve cables on the other.

Using a TRS insert, the effects device would have the insert Send cable plugged into its Input and the insert Return cable plugged into its Output. This wiring

completes the signal loop without interrupting the audio being played through the console.

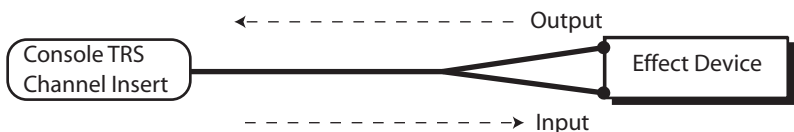

Audio flows from the console insert point into the effect device and then back to the console

To use the AN-16/i with this insert layout, both the In and Thru jacks on the AN-16/i are used. The main console's Insert Send should be plugged into the In jack on the AN-16/i. The Thru jack on the AN-16/i is used to return the signal to the console, completing the audio loop. In this case the AN-16/i acts like an effects device, but it has no audible effect and does not change the audio signal in any way.

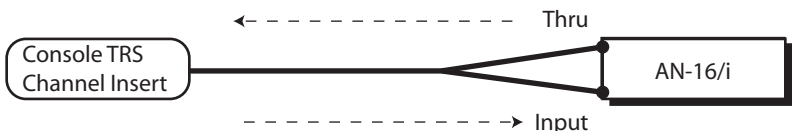

Audio flows from the console insert point into the AN-16/i and then back to the console

Discreet Insert Send and Return Jacks

If a console uses separate jacks for Send and Return functions, the cable connections are much more obvious. The Send from the Insert point on the console is connected to the AN-16/i In jack. The Thru on the AN-16/i is connected to the Return jack on the console to complete the loop. Both balanced and unbalanced versions of this wiring exist on mixing consoles. Consult your mixer's documentation for additional information.



Audio flows from the console Insert Send point into the AN-16/i and then back into the console via the Insert Return

Adding Effects

Console insert points offer a convenient way to patch audio into the AN-16/i Input Module. But, there are times when the insert send/return points will be needed for use with an effect processor such as a compressor. There are some optional ways of both getting audio into the AN-16/i and patching in effects devices.

A-Net Audio Without the Effect

- Connect the console insert Send to an input on the AN-16/i.
- Connect the AN-16/i Thru jack from the same channel as above to the input of the effect processor.
- Connect the output of the effect processor to the console's insert Return jack.

The Send/Return loop on the console is complete. The audio sent thru the Aviom system is *not* processed by the effect device.

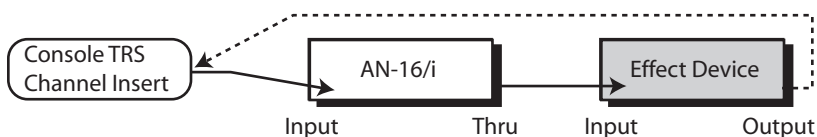

Audio flows from the console insert point into the AN-16/i, then into the effect device, and returns to the console

A-Net Audio With the Effect

- Connect the console insert Send to the input on the effect device.
- Connect the output of the effect processor to an input on the AN-16/i.
- Connect the Thru jack from the same channel as above to the console's insert Return.

Audio passing through the Aviom system is heard *with* the effect processing.

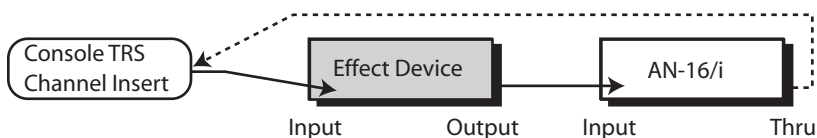

Audio flows from the console insert point into the effect device, then into the AN-16/i, and returns to the console

Line-level Devices

In addition to connecting a traditional mixing console, there are numerous other

audio sources that can be used with the AN-Series audio network products and the Pro16 Monitor Mixing System. There is no requirement that your audio sources be connected to a mixing console first.

Using some creative patching, you'll find numerous uses for the system. Here are a few examples:

- Connect the stereo outputs of multiple CD players to inputs on the AN-16/i Input Module to distribute a variety of music programs to multiple rooms.
- Patch a drum machine output or line output from a computer sound card into the AN-16/i to provide a click track for musicians.
- Connect multiple keyboards directly to the AN-16/i. Then patch the Thru jacks on the AN-16/i to the main mixer inputs.
- Connect outputs from stereo guitar processors or amp simulators.
- Virtual drums can be connected directly into the AN-16/i Input Module.

Connections on the AN-16/o Rear Panel

There are sixteen balanced line-level audio outputs on the rear panel of the AN-16/o Output Module. They can be connected to any device capable of using line-level audio sources, such as audio mixers, effect processors, computer sound cards, cameras and recording devices.

The connectors on the AN-16/o Output Module are multipin DB25 jacks. A variety of breakout cables are available that allow the line-level audio signals from the AN-16/o to interface with devices equipped with XLR or TRS inputs.

Two operating levels are possible, controlled by the switches on the front panel of the unit. Use the **LINE** setting to connect to the line-level inputs of consoles, etc., and use the **Mic** setting when the AN-16/o outputs must be plugged into a mic-level input. Channel output level settings are switched in pairs from the front panel of the AN-16/o.

Adding More Audio Outputs

When additional copies of the same audio channels are needed, using A-Net allows easy system expansion. The A-Net Out jack on the back of the AN-16/o can be used to send an exact copy of the audio data being received to as many AN-16/o Output Modules as required—unlimited digital splits.

16 Channels In



This diagram shows a simple system with one AN-16/i Input Module connected to one AN-16/o Output Module. Audio connected to the AN-16/i is delivered to

the AN-16/o via A-Net.

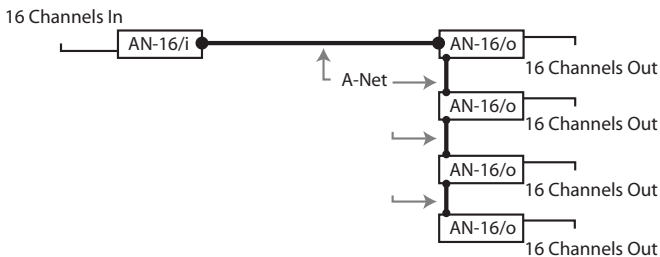

By connecting AN-16/o Output Modules, any number of exact copies of the sixteen channels can be added. Remember, cable runs between devices can be up to 500 feet (150 meters) for added flexibility.

To create a sixteen channel audio network:

- Connect audio from your source to the inputs of the AN-16/i
- Connect the A-Net Out jack on the AN-16/i to the A-Net In jack on the first AN-16/o Output Module.
- Expand the system by connecting a Cat-5e cable from the A-Net Out of the first AN-16/o Output Module to the A-Net In jack on the next AN-16/o Output Module
- Repeat this same patching as needed for each additional AN-16/o added to the network.
- Connect the audio outputs of each AN-16/o to the line-level audio inputs of your receiving devices.

Adding Pro16 Personal Mixers

An audio network can be expanded to include Aviom’s line of Pro16 Monitor Mixing System products as well. As seen in the previous section, the A-Net Out jack on the AN-16/o Output Module can be used to send a copy of the sixteen channels of audio data to another A-Net compatible device. This includes the A-16II and A-16R Personal Mixers.

The following diagram shows a 16 x 16 system with two different types of expanded outputs. It uses both AN-16/o Output Modules and Personal Mixers. Remember that the Personal Mixers can be A-16II or A-16R models as needed.

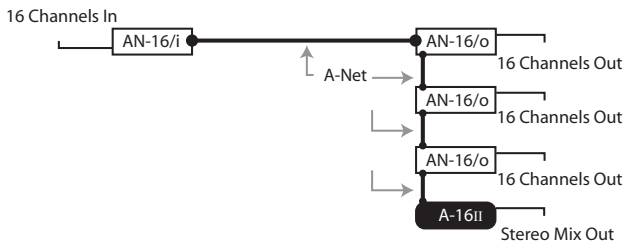

Any number of A-16II or A-16R Personal Mixers can be added using this method. In fact, it's important to remember that *any* A-Net compatible device can be added to a system, connected via daisy-chain or parallel.

Euroblock Connections

AN-Series module equipped with Euroblocks are shipped with the male cable connectors required for installation. The male Euroblock cable connectors plug into the panel jacks on the rear panel and snap into place. The male Euroblock's cable ends can be wired to patch bays, 1/4-inch jacks, XLR cables, or to other terminal block connectors to allow for wiring flexibility.

Wiring can be done without soldering, using simple tools including a wire stripper and small screwdriver. Each panel-mounted Euroblock jack is clearly marked with ground, negative, and positive terminals (left to right) for fully balanced operation. Make sure when connecting cables to the male connectors that the orientation of the individual wires remains the same.

To wire a Euroblock connector:

- Strip the protective outer jacket from the wire using wire strippers to expose the individual wires beneath.
- Strip about 1/4 inch of the insulation from the positive and negative wires (the ground wire typically has no insulation).
- Remove the male Euroblock connectors from the rear panel of the AN-Series module.
- Orient the male Euroblock so that the three screw terminals are facing up.
- Starting from the left side of the connector, insert the *ground* wire into the first slot.
- Use a small screwdriver to tighten the locking mechanism and hold the wire firmly in place.
- Insert the *negative* wire into the second slot in the connector and tighten its screw.
- Insert the *positive* wire into the third slot in the connector and tighten its screw to complete the connections.
- Push the completed male connector into one of the Euroblock jacks on the rear panel of the AN-Series module with the screw terminals facing **up**. The connector snaps into place when properly seated.

Unlike the TRS-equipped version of the AN-16/i Input Module (which has a separate row of TRS Thru connectors), the Euroblock version of the AN-16/i has only one set of connections on the rear panel. To use the Thru feature on a Euroblock model, simply add the wires for the Thru connection to the existing wires in the Euroblock male connector. To do this requires that each screw terminal be loosened so that the second set of wires can be added. Re-tighten the screw terminals to complete the Thru connections.

Audio Networks

When more than sixteen channels of audio are required in an audio network, there are several options available. Systems using sixteen or thirty-two audio channels can be configured with no additional hardware. For systems larger than thirty-two channels, Aviom offers the AN-16SB System Bridge as an option. The System Bridge allows up to four A-Net streams to be combined into a single Cat-5e cable for distribution over long distances.

32-Channel Systems

Aviom's audio network products work in modules of sixteen channels. Audio networks of thirty-two channels can be configured as:

- 32 channels send by zero channels return (32 x 0)
- 16 channels send by 16 channels return (16 x 16)
- 0 channels send by 32 channels return (0 x 32)

The descriptions above are similar to those used for traditional multi-core analog audio snakes. The configurations refer to the number of audio channels used as inputs on each side of the snake. For example, the "32" in the 32 x 0 configuration means that 32 audio inputs can be connected at the stage to send to the front-of-house (FOH) mix position. The "0" means that on the there are no audio inputs that can be used to send audio back to the stage position.

A thirty-two channel system is comprised of four AN-Series units, two AN-16/i Input Modules and two AN-16/o Output Modules. Since the system is modular, you can connect the AN-Series units as needed, making any of the configurations mentioned previously available at any time. Simply move and re-patch the units.

A-Net Expansion

In a thirty-two channel system, the A-Net Expansion jack is used to combine two A-Net data streams into a single steam that can travel down one cable. At the receiving end of the audio network, the A-Net Expansion jack is used again to separate the data into individual 16-channel data streams.

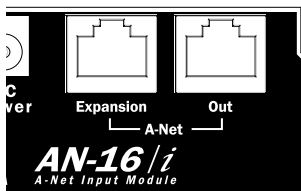

Some points to remember about using the A-Net Expansion jacks on the AN-16/i

and AN-16/o to create an audio network:

- When creating a network with four AN-Series units, one A-Net Expansion jack will be connected to an A-Net *In* port while the other A-Net Expansion jack will be connected to an A-Net *Out* port.
- The A-Net *Out* jacks on the AN-16/o Output Modules should be empty when only four AN-Series units are being used to create a network. These are then available for adding extra AN-16/o Output Modules for digital splits or for connecting to a Pro16 Monitor Mixing System.
- The cable connecting the two sides of the network (carrying thirty-two channels of audio) should be connected to one A-Net *In* port and one A-Net *Out* port.
- Do not connect Cat-5e cables carrying expanded system data (more than 16 channels) to an A-16D or A-16D Pro Distributor or Personal Mixer product.
- The maximum cable length specification of 500 feet (150 meters) applies to the length between an A-Net *In* port and an A-Net *Out* port. Cables used to connect devices via the A-Net Expansion jacks must fall within this maximum distance.
- An A-Net Expansion port is *never* connected to another A-Net Expansion port.

32 Channels Send

The 32 x 0 configuration has all audio inputs on one side of the audio network and all audio outputs on the other side.

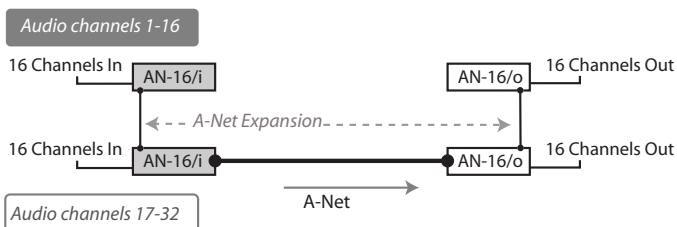

With this configuration, two AN-16/i Input Modules receive up to thirty-two analog audio signals as inputs. One AN-16/i contains channels 1-16, while the other has channels 17-32.

To configure a 32 x 0 system:

1. Connect the first sixteen line-level audio sources to inputs 1-16 on the first AN-16/i Input Module.
2. Connect the second group of sixteen audio sources to inputs 1-16 on the second AN-16/i.
3. Connect a Cat-5e cable from the A-Net Out jack on the first

- AN-16/i to the A-Net Expansion jack on the second AN-16/i.
4. Connect a cable from the A-Net Out jack on the second AN-16/i and run it to the destination where the AN-16/o Output Modules are located, and plug it into the A-Net In jack on the first AN-16/o Output Module.
 5. Connect a Cat-5e cable from the A-Net Expansion jack on the first AN-16/o to the A-Net In on the second AN-16/o.
 6. Patch the audio outputs from the two AN-16/o Output Modules into the desired destinations.

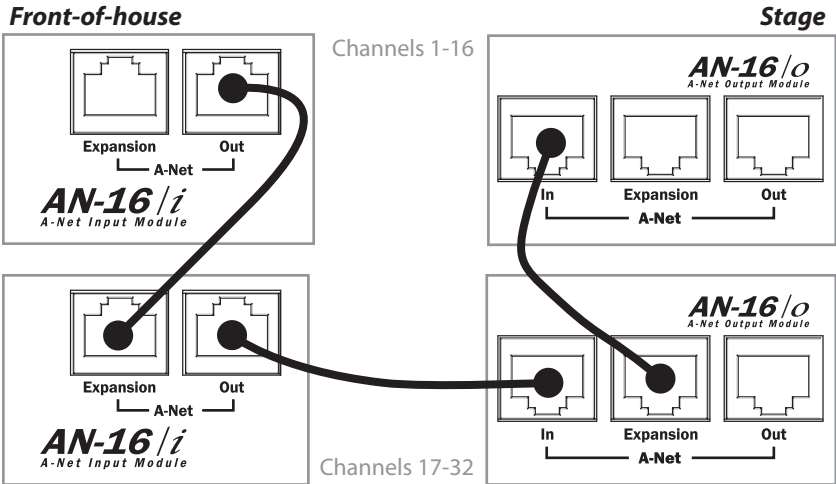

Cat-5e connections for a 32 x 0 system, shown in a live performance setting

Remember that the maximum cable length between A-Net devices is 500 feet (150 meters).

16 Channels Send/Return

The 16 x 16 configuration has sixteen inputs and sixteen outputs on each side of the audio network.

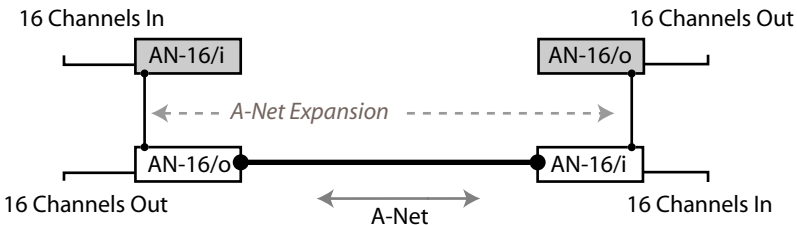

Using this configuration, each side of the audio network has one AN-16/i Input Module and one AN-16/o Output Module. Sixteen channels of audio move in

each direction over a single Cat-5e cable.

Again, the A-Net Expansion jack is used to combine the A-Net data from two devices for transmission down one cable.

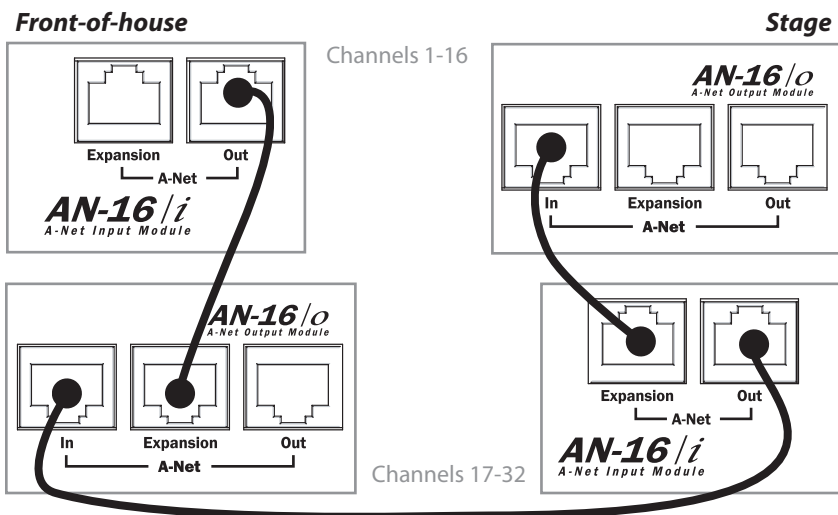

To configure a 16 x 16 system:

1. Set up one AN-16/i and one AN-16/o on each side of the network. (For example, one set of an AN-16/i and an AN-16/o is placed at the front-of-house mix position. The matching set of one AN-16/i and one AN-16/o is placed on the stage.)
2. Connect sixteen line-level audio sources to inputs 1-16 on the first AN-16/i.
3. Connect a Cat-5e cable from the A-Net Out jack on the first AN-16/i to the A-Net Expansion jack on the first AN-16/o.
4. Plug a Cat-5e cable into the A-Net In jack on the first AN-16/o Output Module. This cable will be used to span up to 500 feet between the two sides of the network.
5. Connect the cable from the A-Net In jack in Step 4 to the A-Net Out jack on the second AN-16/i Input Module.
6. Connect the second group of sixteen audio sources to inputs 1-16 on the second AN-16/i.
7. Connect a Cat-5e cable from the A-Net Expansion jack on the second AN-16/o to the A-Net In on the second AN-16/o.
8. Patch the audio outputs from the two AN-16/o Output Modules into the desired destinations.

Adding More Audio Outputs

As mentioned previously, the A-Net Out jacks on the AN-16/o Output Modules remain available even when creating a bidirectional audio network. This allows additional output modules to be added as needed to suit a variety of audio situations. Any A-Net compatible product can be added to an A-Net Out port. This flexible routing scheme allows you to send audio to a variety of different locations, and to include Aviom's Pro16 Monitor Mixing System for performers.

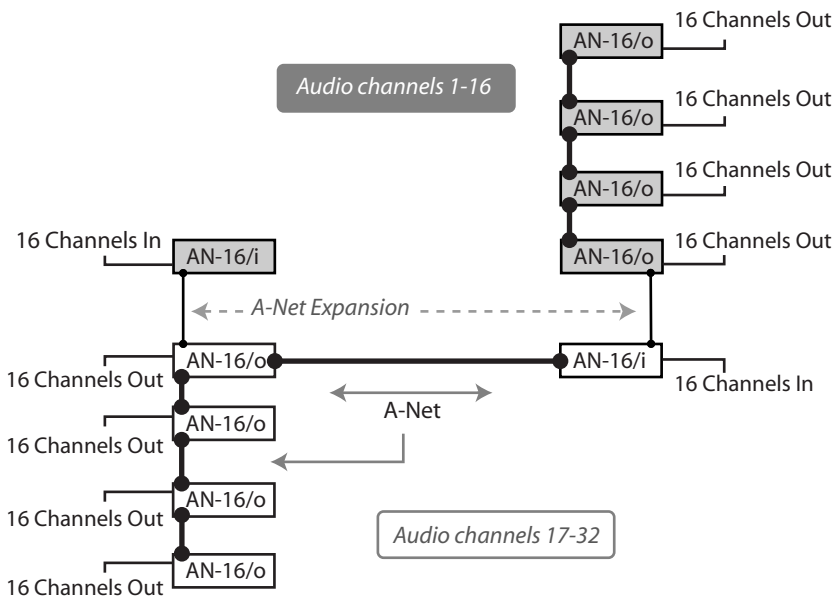

In this example, a 16 x 16 network has been expanded to include three additional AN-16/o Output Modules on each side of the network. Each AN-16/o is connected via A-Net using a Cat-5e cable. Remember that the cable lengths between each A-Net device can be up to 500 feet (150 meters) long.

To create an expanded network:

- First start by configuring the network according to your basic needs (either as 32 x 0 or 16 x 16).
- Add additional AN-16/o Output modules by connecting a Cat-5e cable from the A-Net Out port on one of the connected AN-16/o Output Modules to the A-Net In port on an AN-16/o Output Module that you want to use to expand the system.
- Each additional AN-16/o that you want to add is connected by patching a Cat-5e cable from the A-Net Out jack on the module preceding it to its A-Net In jack.

Adding an A-16D Distributor

While the A-16D A-Net Distributor is not compatible with the data being generated by the A-Net Expansion ports on the AN-16/i and AN-16/o, you can use an A-16D (or A-16D Pro) to add wiring flexibility to your system.

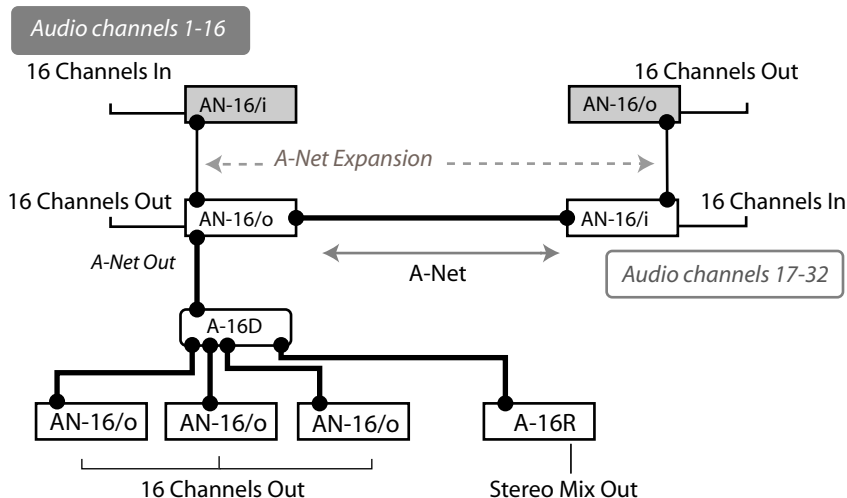

In this diagram, an A-16D or A-16D Pro Distributor receives A-Net from an AN-16/o Output Module connected to a network configured as 16 x 16. In the example, only audio channels 17-32 are being redistributed to the additional A-Net devices. From the A-16D, up to eight A-Net devices can be connected. The diagram shows three AN-16/o Output Modules connected. Each can provide sixteen line-level outputs. Also, an A-16R rack mounted Personal Mixer is shown. The A-16R can be used to mix and monitor the same audio content in stereo. The Cat-5e cable run between the AN-16/o and the A-Net Distributor can be up to 500 feet long, as can the cable from the A-16D to the A-Net devices connected to it.

64-Channel Systems

When used with the optional AN-16SBR System Bridge, the AN-16/i Input Module and AN-16/o Output Module can create audio networks of up to sixty-four channels. Up to four AN-16/i Input Modules and four AN-16/o Output Modules can be used in a variety of combinations to create a flexible and reconfigurable audio distribution network.

Aviom's audio network products work in modules of sixteen channels. Distributed audio networks of up to sixty-four channels can be configured as:

- 64 channels send by zero channels return (64 x 0)

- 48 channels send by 16 channels return (48 x 16)
- 32 channels send by 32 channels return (32 x 32)
- 16 channels send by 48 channels return (16 x 48)
- 0 channels send by 64 channels return (0 x 64)

The AN-16/i-M Mic Input Module can be substituted for any AN-16/i shown in the following diagrams. Use the AN-16/i-M to add up to sixteen microphone signals per module to a audio network. Digital modules—the Y1 card for Yamaha and the D-16c card for DiGiCo—can be substituted for input modules in the diagrams that follow.

Note: When using the System Bridge to create a network, the Expansion jacks on the AN-16/i and AN-16/o are not used.

System Bridge

The AN-16SBR System Bridge (and its predecessor, the AN-16SB) is a two-part accessory that takes in up to four individual A-Net data streams and combines them for transmission over a single Cat-5e cable. At the destination, another AN-16SBR is used to separate the A-Net streams. The separate A-Net data streams can then be connected to A-Net compatible devices as needed.

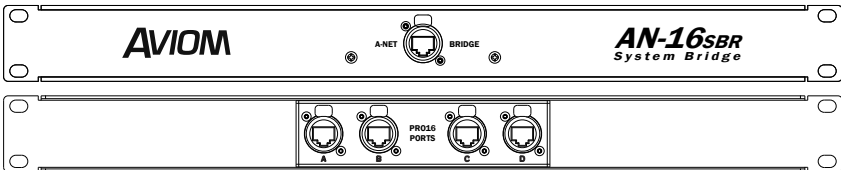

The front and rear panels of the rack-mounted AN-16SBR.

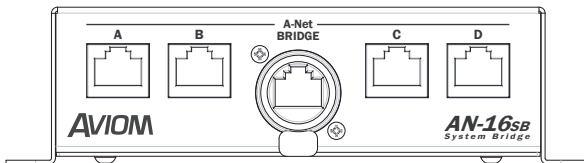

The front panel of the original AN-16SB.

The System Bridge contains four A-Net connectors labeled A, B, C, and D. These accept standard Cat-5e cables. These jacks will always connect to an A-Net compatible product.

The connection labeled *A-Net Bridge* will always connect to another System Bridge's A-Net Bridge connector.

Connecting the System Bridge

Adding a System Bridge to an audio network is quite simple. Two System Bridges are needed to create a network. The four A-Net connectors (labeled A, B, C, and D) on one side of the network are directly related to the A, B, C, and D connectors on the other side of the network. That is, if you patch an AN-16/i Input Module into port "A" on one side of a System Bridge, an AN-16/o Output Module would be connected to port "A" on the other side of the System Bridge. See the following diagram. (Note that in the diagrams either the AN-16SB or AN-16SBR can be used.)

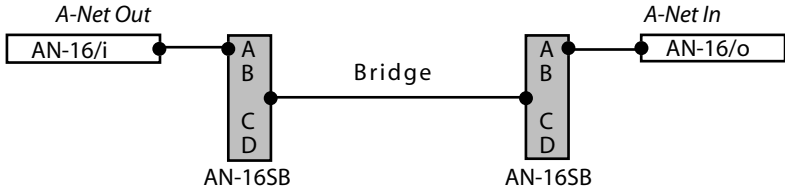

This diagram shows the relationship of the A, B, C, and D ports on the AN-16SB.

A complete network using four units per side follows the same pattern. An AN-16/i Input Module connected to port B on one side of the network connects to an AN-16/o Output Module via port B on the other side of the network. The same goes for ports C and D, as seen in the following diagram.

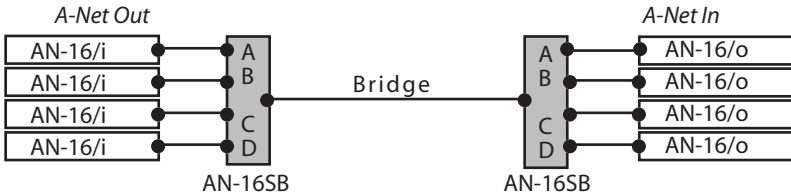

A-Net ports A, B, C, and D are shown connected in a 64 x 0 network configuration

To connect a 64 channel network (64 x 0):

On the Send side

- Connect a Cat-5e cable from the A-Net Out of the first AN-16/i to port A on the first System Bridge
- Repeat this process to connect the A-Net out from the remaining three AN-16/i Input Modules to ports B, C, and D.

On the Receive side

- Connect a Cat-5e cable from port A on the second System Bridge to the A-Net In jack on the first AN-16/o Output Module.
- Repeat this process to connect ports B, C, and D to the remaining AN-16/o Output Modules.

Connect the two sides of the system by running a Cat-5e cable (with or without an EtherCon connector) between the two A-Net Bridge jacks on the System Bridges.

To use other configurations, simply move any pair of AN-16/i and AN-16/o units.

In the following example, the devices connected to port D on the System Bridge have been swapped to create a 48 x 16 system.

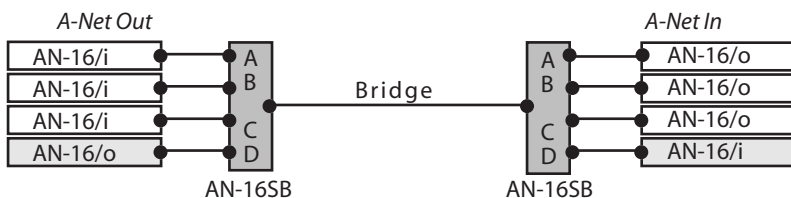

A 48 x 16 system is created by exchanging the units connected to port D on the System Bridge.

Remember, the total cable length between A-Net devices should not exceed 500 feet, 150 meters. Cables used to connect A-Net devices to the System Bridge are included in this calculation.

Configuration Notes

When configuring 64-channel systems that send data in both directions, Aviom suggests the following module combinations. While not mandatory, these suggestions are made to accommodate the standard wiring practices that Ethernet uses. (Aviom's A-Net technology is based on Ethernet.) Some wire pairs in a standard Ethernet cable are not next to each other inside the jacket of the cable. This can account for slightly higher data errors in rare cases.

The configuration recommendations apply to systems configured as 16 x 48 and 32 x 32, not those sending data in only one direction. The module combinations are applicable especially when using long cable runs.

For 16 x 48 (or 48 x 16) configurations, place the three similar modules together, connected to either ports A, B, and C on the System Bridge or to ports B, C, and D. See the following diagrams.

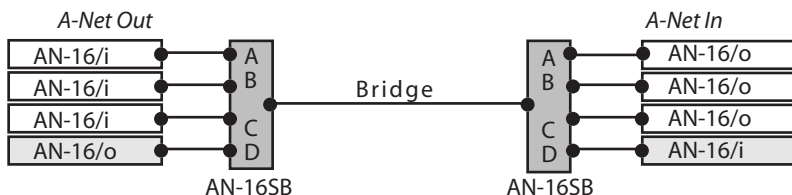

Ports A, B, and C use the same type of module.

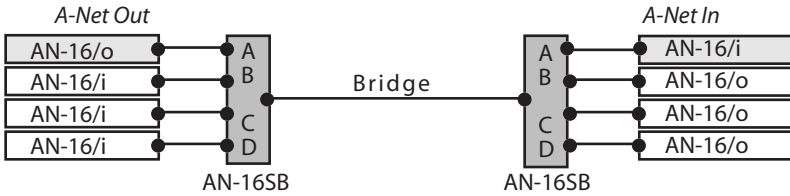

Ports B, C, and D use the same type of module.

For a 32 x 32 16) configuration, place two similar modules together, connected to either ports B, and C on the AN-16SB. The modules connected to ports A and D are also similar by doing this configuration., See the following diagram.

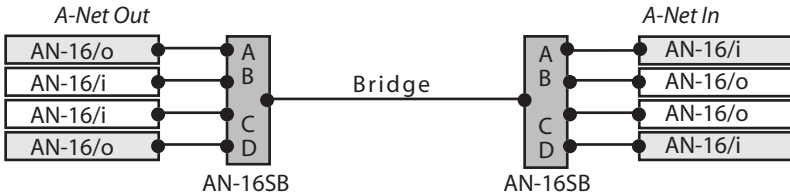

Ports A, and D use the same type of module; ports B and C contain the same type of module.

Note that the total A-Net cable length between devices is limited to 500 feet.

Expanding a Network

As mentioned in the section on 32-channel systems, any available A-Net Out jack on an A-Net device can be used to expand an existing system. Any number of additional AN-16/o Output Modules can be added, as can any number of A-16II or A-16R Personal Mixers.

The following example shows one variation of an expanded system.

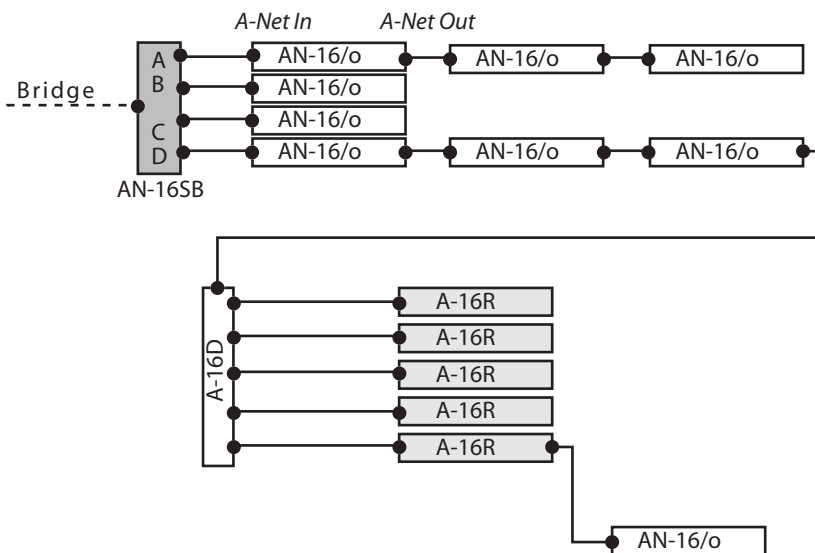

This example starts as a 64 x 0 configuration (the input side of the system is not shown in the diagram). Two of the outputs are expanded. Port A has two AN-16/o Output Modules added. Port D has two Output Modules which then feed an A-16D A-Net Distributor.

The A-16D Distributor connects to five A-16R rack mounted Personal Mixers for use as a monitor system for five musicians performing live. Then, another AN-16/o Output Module is connected via a daisy chain to the last A-16R.

Expansion of a system can continue as your needs require. Any available A-Net Out can be used to connect to the A-Net In on any compatible device.

Again, each A-Net cable used can be up to 500 feet long, making this system capable of spanning long distance, between rooms, floors, etc. A-16D Pro A-Net Distributors can be substituted for the A-16D.

Using Multiple System Bridges

Expansion of a system can include multiple AN-16SBR (or AN-16SB) System Bridges. This allows audio to be fed to different locations as needed. Using multiple System Bridges follows the same connection rules as outlined previously. (Port A on one System Bridge always connects data to Port A on another System Bridge, etc.)

System Bridges can also be used to combine A-Net streams from multiple networks in an installation, allowing, for example, ports A and B from Network #1 to be sent along with streams B and C from Network #2 to a third area, creating Network #3.

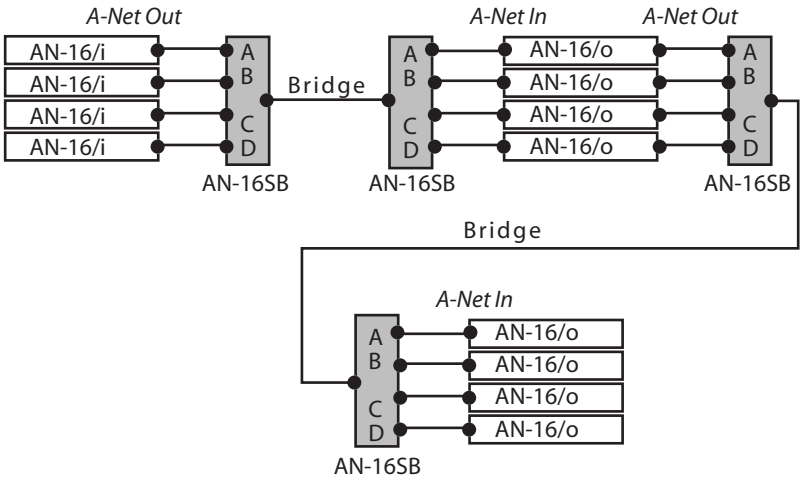

A second set of System Bridges move 64 channels of audio over one Cat-5e cable to another destination.

The next example shows a complex network that combines A-Net from two different networks

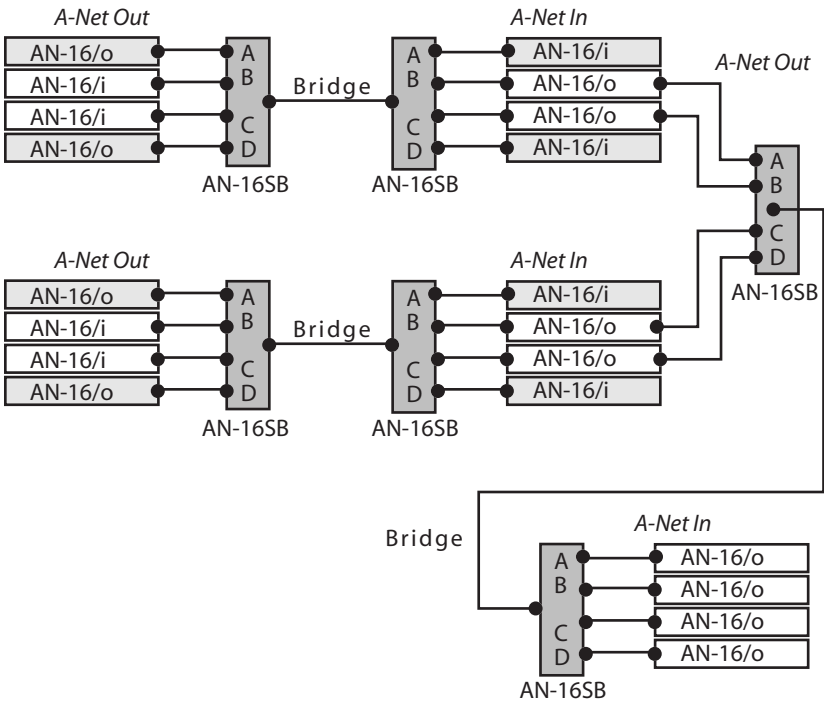

As with all A-Net compatible devices, any available A-Net Out can be used as a starting point for expansion.

In the preceding diagrams, any Pro16 input module can be substituted for the AN-16/i modules. These include:

- AN-16/i-M - 16 mic/line inputs
- Y1 card - for use with Yamaha digital mixing consoles; routes audio from the Yamaha interface to A-Net
- D-16c card - for use with DiGiCo digital mixing consoles; routes audio from the DiGiCo interface to A-Net

Appendix 1

AN-16/o Output Module Variations

Previous versions of the AN-16/o are compatible with all Pro16 products. The information provided here details the differences in features of previous models in order to make the integration of new and old products easy to understand.

Original AN-16/o

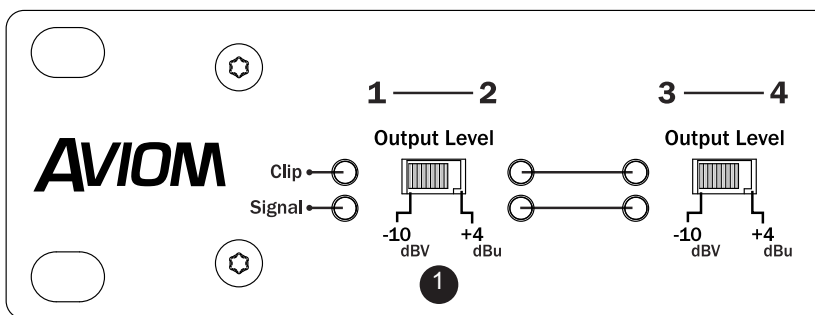

FUNCTION	
1	Output Level Switch - in the left position, the channel pair is output at -10dBv level; in the right position, the channels are output at +4dBu line level

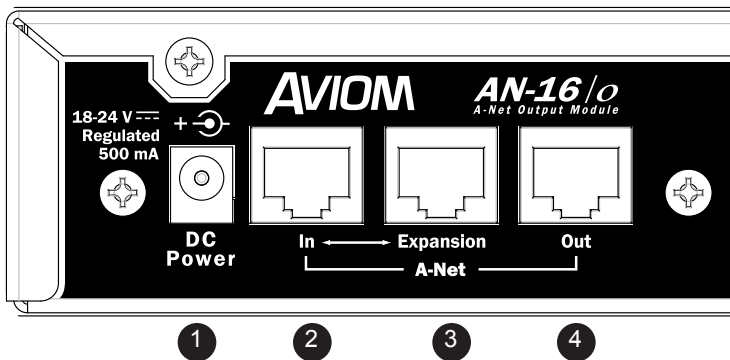

FUNCTION	
1	DC Power Jack - connect the DC power supply here
2	A-Net In Jack - used when creating a 32-channel system with two AN-16/i and two AN-16/o units
3	A-Net Expansion Jack - used when creating a 32-channel system with two AN-16/i and two AN-16/o units
4	A-Net Out Jack - connects to any A-Net compatible device
5	Analog Audio Outputs - TRS balanced 1/4" jack supplies a -10dBu or +4dBV line level audio signal (for TRS model only)
6	Euroblock outputs (for EB model only)

TRS model rear panel

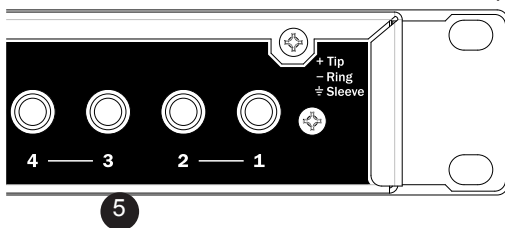

Euroblock model rear panel

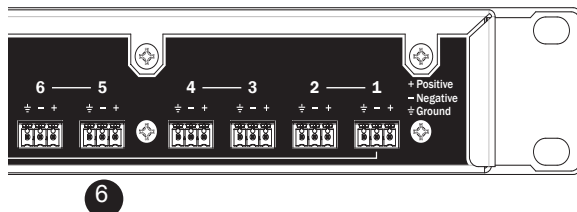

Original AN-16/o Output Module Front Panel

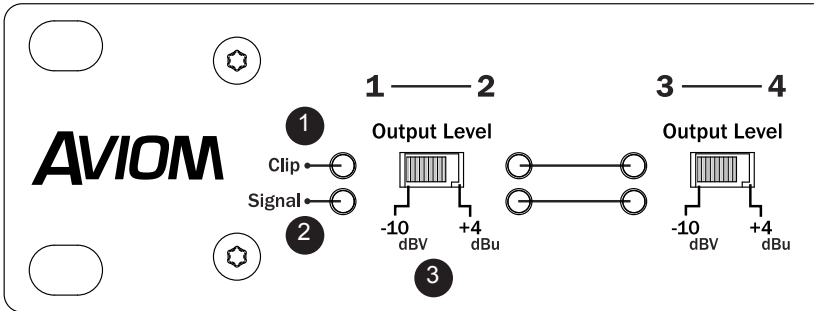

FUNCTION	
1	Clip LED, red - lights when the audio signal hits (0dB) full scale, indicating that the source audio signal is too high.
2	Signal Present LED, green - lights to show that an audio signal is present on a channel
3	Output Level Switch - in the left position, the channel pair is output at mic level; in the right position, the channels are output at +4dBu line level
4	Power LED - indicates that the AN-16/o is on
5	A-Net LED - indicates that the AN-16/o is receiving valid A-Net data

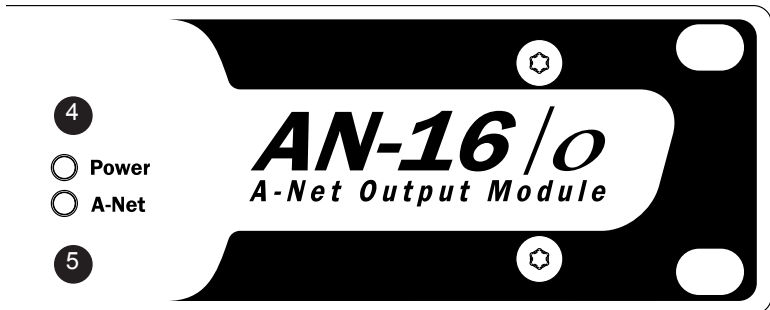

Original AN-16/o Output Module Rear Panel

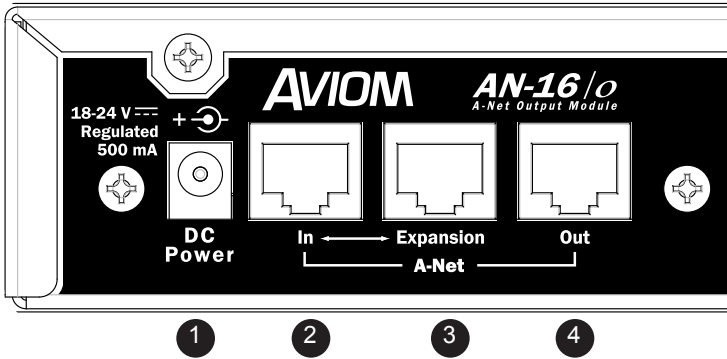

FUNCTION	
1	DC Power Jack - connect the DC power supply here
2	A-Net In Jack - connect the A-Net signal from an input module or other compatible A-Net source here
3	A-Net Expansion Jack - used when creating a 32-channel system with two AN-16/i and two AN-16/o units
4	A-Net Out Jack - connects to any A-Net compatible device
5	Analog Audio Outputs - TRS balanced 1/4" jack supplies a -10dBu or +4dBV line level audio signal (for TRS model only)
6	Euroblock outputs (for EB model only)

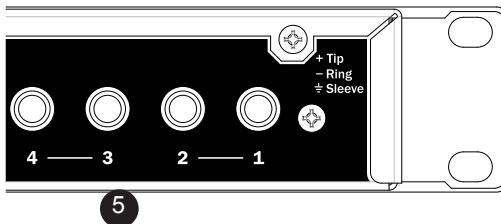

TRS model rear panel

Euroblock model rear panel

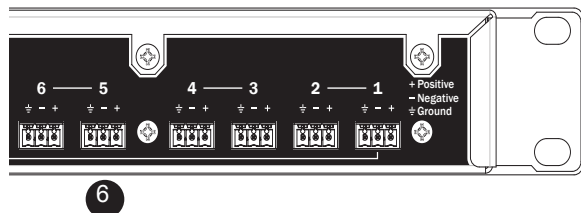

Appendix 2

DB25 Wiring Info

The rear panel of the AN-16/o uses a pair DB25 connectors for its balanced line-level audio outputs.

AN-16/o DB25 Audio Connections

The DB25 multi-pin connectors on the AN-16/o are wired to analog pinout standards. This allows easy interfacing with a variety of audio equipment with the use of readily-available multi-pin breakout cables or with Aviom PB28 Modular Patch Bay products.

Each DB25 jack carries eight balanced audio channel outputs.

To wire a custom cable for use with the AN-16/o DB25 output jacks, use the following table:

Cable Number	DB25 Pin Number		
	Hot	Cold	Ground
1	24	12	25
2	10	23	11
3	21	9	22
4	7	20	8
5	18	6	19
6	4	17	5
7	15	3	16
8	1	14	2
No Connect	13		

DB25 Pinout

The pins on panel-mounted DB25 jacks on the AN-16/o are numbered according to the following diagram.

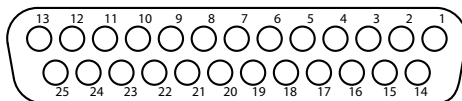

Each DB25 jack carries eight of the balanced line-level audio signals—channel 1-8 or channels 9-16.

Warranty Registration

Please take a moment to fill in this warranty registration form. Return it to Aviom via mail or fax. All information will be kept confidential.

Model Number Product Serial Number

Model Number Product Serial Number

Model Number Product Serial Number

Model Number Product Serial Number

Date Purchased

Dealer Name

Dealer Location

.....

Your Name

Address

Address

City

State/Province

Zip/Postal Code

Country

Email Address

Fax this form to Aviom at +1 610-738-9950

Index

Symbols

- +22dB 15
- +4dB 15
- 10dBV 15
- 0dBu 15
- 32-Channel System 32
- 64-Channel System 37, 40

A

- A, B, C, D ports
 - System Bridge 38
- A-16CS Control Surface 16
- A-16D 2, 21, 22, 33, 37, 42
- A-16D Pro 2, 21, 22, 37, 42
- A-16II 16, 31, 41
- A-16R 16, 30, 31, 37, 42
- A-Net 7, 36
 - Bridge 40
- A-Net Active LED 17
- A-Net Bridge 40
 - AN-16SB, AN-16SBR 38
- A-Net Connections
 - AN-16/i 17
- A-Net Connectors 21
- A-Net Distributor 2, 22, 37, 42
 - A-16D, A-16D Pro 21
- A-Net Expansion 21, 32, 33, 35
 - AN-16/i 17
- A-Net Expansion jack 32
 - AN-16/i 11
 - AN-16/o 13, 46, 48
- A-Net In 21, 42
- A-Net LED 12, 47
 - AN-16/o 12, 47
- A-Net Out 21, 29, 42
 - AN-16/i 17
- A-Net Out jack
 - AN-16/i 11
 - AN-16/o 13, 46, 48

- AC Line Conditioning 3
- Adding A-16 Mixers 30
- Adding Effects 28
- Adding More Audio Outputs 29, 36
- adding Personal Monitor Mixers 36
- AN-16/i-M 2, 21, 44
- AN-16/i-M Mic Input Module 38
- AN-16/i Front Panel 14
- AN-16/i Rear Panel 23
- AN-16/o
 - front panel 12, 47
- AN-16/o Front Panel 19
- AN-16/o model variations 45
- AN-16/o Rear Panel 20, 29
- AN-16SBR System Bridge 3, 38
- AN-16SB System Bridge 3, 7, 32, 37, 38
 - using multiple 42
- AN-Series 2
- Analog audio input
 - AN-16/i 11
- Analog audio outputs 13, 46, 48
- audio network 30
- Audio Networks 32
- Audio Outputs 21
- audio outputs 13, 46, 48
- audio Thru 17
- Aux Sends 25
 - pre/post-fader 26

B

- balanced 11, 13, 21, 23, 46, 48
- Balanced signals 18
- bidirectional 36
- Bridge 38, 40
 - A-Net 40
- Bus Output 24, 25

C

- cable length 6, 40
- Cat-5 5, 6
- Cat-5e 2, 5
- Cat-6 2
- Category 5 5
- Category 5e 5
- Category 6 5
- Channel Input Jacks 18
- Channel LEDs 14, 19
- Channel Thru Jacks 18
- Cleaning and Maintenance 9
- Clip LED 10, 12, 14, 19, 47
- computer network 7
- Configuration Notes 40
- Connecting a Mixer 23
- Connecting Audio 23
- Control Surface 16
- crossover cables 6

D

- D-16c 21, 38, 44
- d-sub 1, 21
- daisy-chain 21, 31
- daisy chain 42
- DB25 1, 21, 29
 - wiring diagram 49
- DB25 Wiring Info 49
- DC Power Input 20
- DC Power Jack
 - AN-16/i 11
 - AN-16/o 13, 46, 48
- DC power supply 8
- DiGiCo 21, 38
- digital split 21, 29
- Direct Output 23
- Distributor 22

E

- effect processor 28
- effects device 26, 28
- effects device outputs 15

- Effects Send 25
- EtherCon Connector 4
- Ethernet 7
- Euroblock 17, 18, 23, 31
- Euroblock inputs 46, 48
- expanded network 36
- Expanding 41
- Expansion 18
- Expansion jack 33, 38

F

- Front/Rear Panel Diagrams 10
- Front Panel
 - AN-16/i 10, 14
 - AN-16/o 12, 19, 47

G

- group output 24
 - console 24

I

- inline coupler 7
- Input jacks 18
- Input Levels 14
- Input Level Switch 10, 14
- insert points 28
- Insert Send/Return 26, 27
- Installing in a Rack 4

L

- LAN
 - Local Area Network 7
- LED
 - descriptions of 10
- LEDs 14
- Level Switch 15
- Line 29
- line level 21
- Linking Channels 16
- Link Switch 15, 16
- Local Area Network 7

M

- maximum cable length 7, 34
- Mic 29
- Mic Input Module 2, 38
- mixer sub-groups 15
- monitor
 - with effect 28
 - without effect 28
- Mono 16
- multi-pin connectors 49

N

- network 7
- networking 7
- Neutrik 4

O

- operating levels 29
- output jacks 21
- Output Level Switch 19
 - AN-16/o 12, 45, 47

P

- Package Contents 3
- Parallel A-Net Routing 22
- parallel connection 22
- Patch Bay 49
- PB28 Modular Patch Bay 49
- permanent installation 5
- Personal Mixer 33, 36, 41
- Personal Mixers 15, 16
 - adding 30
- pinout diagram
 - DB25 49
- Power Connector 17
- Power LED 16
 - AN-16/i 10
 - AN-16/o 12, 47
- power supply 17, 20
 - plug size 8
 - replacing 8
- power supply polarity 8
- Pro16 7

- Personal Mixers 15
- Pro16 Monitor Mixing System 36
- Pro16 Personal Mixers
 - adding 30

R

- rack-mounting screws 4
- Rack mounting 4
- Rear Panel
 - AN-16/i 11
 - AN-16/o 13, 20, 48
- replace the power supply 8
- RJ45 4
- RJ45 connector 5
- router 7

S

- Send/Return Points
 - insert 26
- series connection 21, 22
- Signal LED 10, 12, 14, 19, 47
- stereo channel 15
- stereo input 15, 16
- Stereo Link 15, 16
- Stereo Link Switch 10
- Submixing 24
- System Bridge 3, 32, 38
 - using multiple 42

T

- Thru 17, 31
- Thru jack 18
 - AN-16/i 11, 27
- Tip, Ring, and Sleeve 18
- TRS 18, 23
- TRS balanced 11, 13, 46, 48
- TRS Inserts 26

U

- unbalanced 18, 23
- UPS 3
- Using Multiple System Bridges 42

W

wire a DB25 cable 49

wire a Euroblock connector 31

X

XLR 31

Y

Y1 38, 44

Y1 card 21

Yamaha 21, 38

Y cable 26