

hear back™ MASTER HUB #1

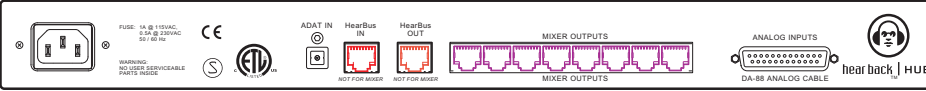

UP TO 31 ADDITIONAL HUBS

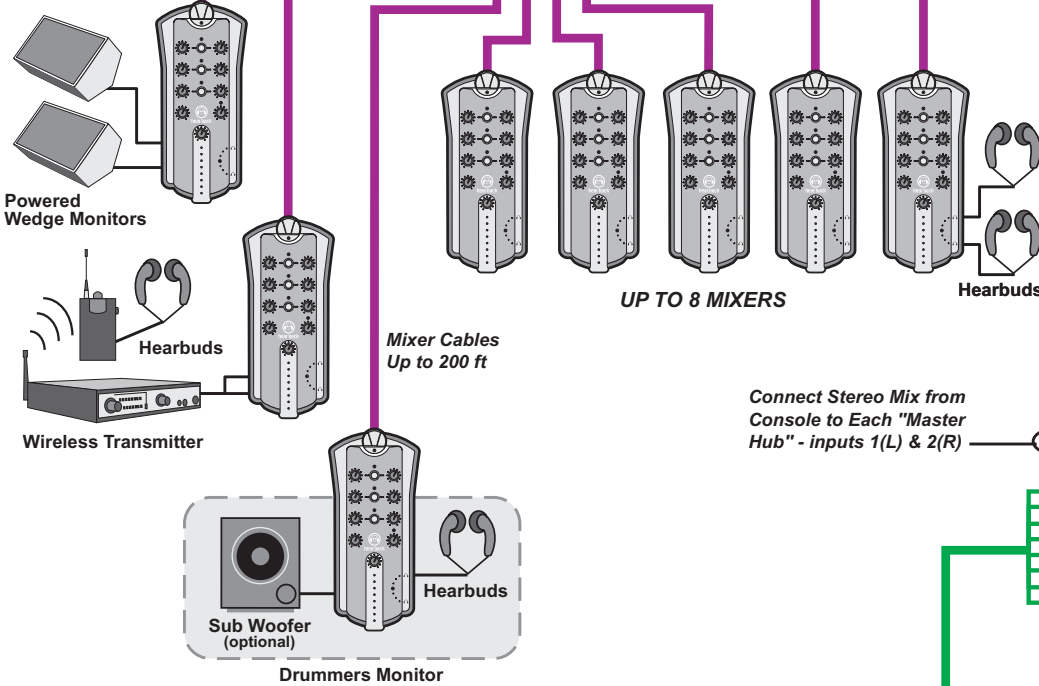

UP TO 8 MIXERS

Connect Stereo Mix from Console to Each "Master Hub" - inputs 1(L) & 2(R)

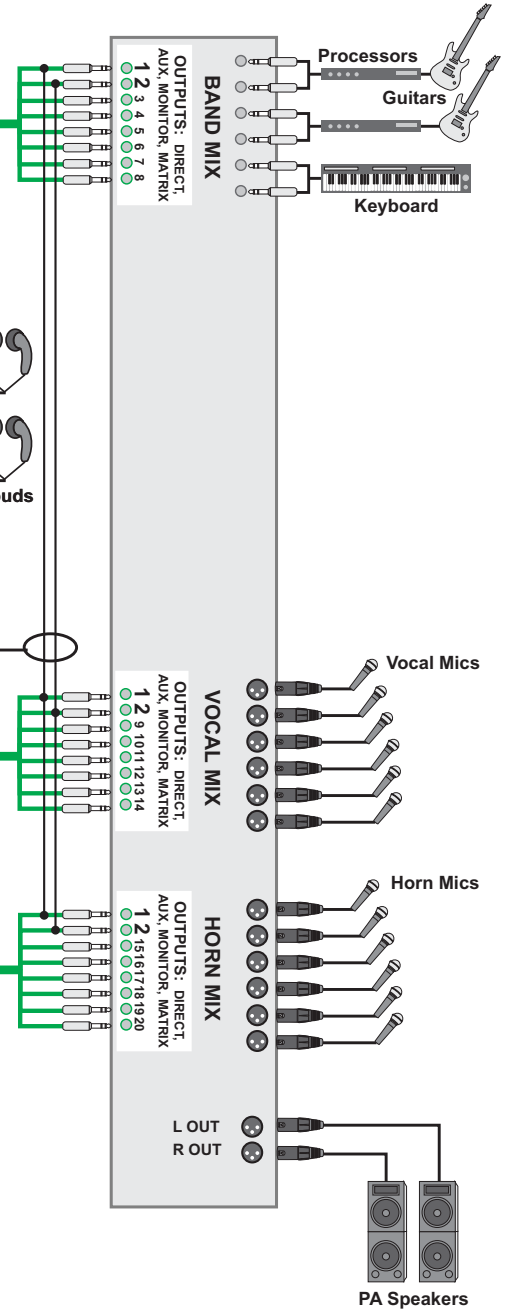

hear back™ MASTER HUB #2

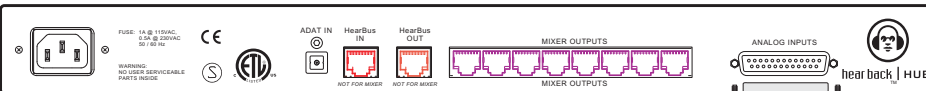

UP TO 31 ADDITIONAL HUBS

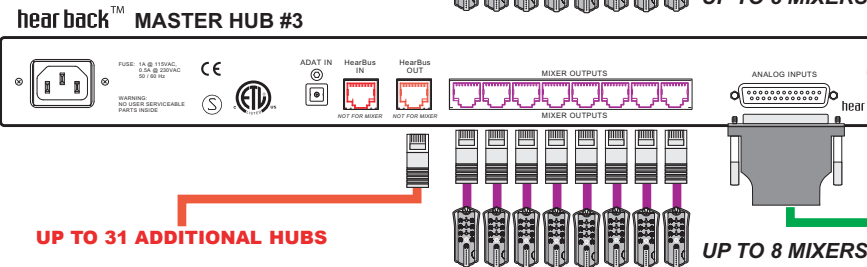

UP TO 8 MIXERS

UP TO 8 MIXERS

NOTE: Each hub gets the stereo mix and sectionals. Each master hub can have 31 hubs daisy-chained from it.